

# MUSCLE TOOLS

Electronic Diagnostics | Special Tools | Shop Equipment | A/C Tools

Q4 2014 Edition



## Exceptional Tire Changer Closeout Pricing!

**Customer Savings**



**TCE4230**  
**Regular Price:** \$4,895  
**Promo Price:** \$3,995  
**Plus Rebate** \$500  
**Promo Price after rebate** \$3,495

**A \$1,400 Value**



**TCE4230SFA**  
**Regular Price:** \$6,895  
**Promo Price:** \$5,995  
**Plus Rebate** \$500  
**Promo Price after rebate** \$5,495

**A \$1,400 Value**



**TCE4335THP**  
**Regular Price:** \$7,995  
**Promo Price:** \$6,995  
**Plus Rebate** \$650  
**Promo Price after rebate** \$6,345

**A \$1,650 Value**

While Supplies Last

## Other Wheel Service Rebates

**Gift Card Rebates:**

**\$500 WBE 4230**

**\$1,500 FWA 4437, FWA 4630**



Visit [www.Boschrebates.com](http://www.Boschrebates.com) to redeem. Available in US and Canada.

Extended to Dec. 31, 2014

## THE HEAVY-DUTY TOOL: 3824 BOSCH ESI[truck]

The most complete diagnostic coverage for multibrand heavy-duty trucks and engines, performing special tests and parameter reset capabilities. Use one tool to test, troubleshoot and see repair information. Diagnose vehicle, engine, transmission and brake problems.

### RUGGEDIZED OE-LEVEL DIAGNOSTICS PC TABLET

Featuring Windows® 7 operating system that supports multitasking & separate RP1210 Communication Device.

### ADDITIONAL COVERAGE

Trailer ABS Controllers; Allison & Eaton Transmissions.

### THE MOST COMPLETE HD DIAGNOSTIC COVERAGE

Trucks: Freightliner, International, Kenworth, Mack, Volvo, Peterbilt, Sterling, Westernstar, MD Trucks (Freightliner Sprinter Van, Isuzu, GM and Ford).

### ENGINE COVERAGE

Heavy-duty engines – Caterpillar, Cummins, Detroit Diesel-MBE, Deutz, Mack, MTU, Navistar, PACCAR, Perkins and Volvo. Medium and light duty engine software included.

### HEAVY & MEDIUM DUTY FUNCTIONS

Read and clear codes, calibrations, diagnostics, track service schedules, data stream, component technical data, actuators and tests, wiring diagrams, system data, repair reports, parameter settings and repair information. Also includes OBD scan for pick-up trucks.



**3824 WINDOWS 7 TABLET SCAN TOOL**  
 Includes VCI, 6 pin and 9 pin cables

**3824BSC SCAN KIT**  
 • Use with your shop PC  
 • Includes Bosch diagnostic software, VCI, 6 and 9 pin cables.

**NEW**

## OTC Smart Battery Tester tests batteries, starting and charging systems with smart device

Download the OTC3200 app from the Google Play or iTunes store. View battery test data by scanning the device QR code\*. Instructions included on testing device.

- All light duty applications - test 6V, 8V and 12V lead acid and AGM batteries
- Diagnose bad batteries faster – an internal 9V battery allows testing for deeply discharged batteries
- Share your test results – print, save or email a customer friendly color report
- Confidently recommend repairs – use your smart phone or tablet camera to embed photos into customer reports
- Tool allows you to start vehicle to perform charging and starting system diagnosis
- Tool can also be used alone to quickly retrieve open circuit voltage and CCAs
- Sync feature sends information to all phones used in your shop so every tech can access reports by vehicle.

\*Smart devices paired with the tester must have auto-focusing rear-facing camera to meet full requirements

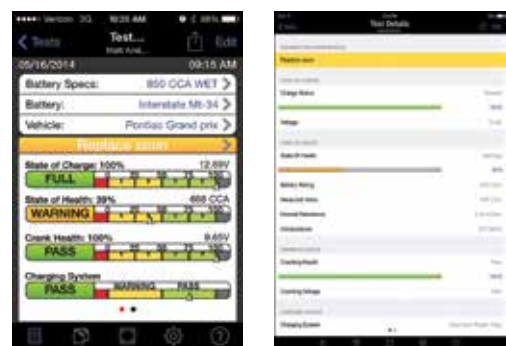

Customer Friendly Report

Technician Detail Report

Watch the tool used at a local shop on a 2000 Celica here:



## Getting better all the time

Check out the latest software updates, improvements, new coverage and features to OTC's line of professional scan tools.

### OTC Encore

- Find the fix in seconds with the industry's fastest diagnostics flow.
- Now with TPR/TPMS and Heavy-Duty.
- Available October 2014: Battery Disconnect Procedures, Key fob and Remote Reprogramming.

### OTC Genisys Touch

Get the most of your 12-month subscription by updating your tool. The latest updates include:

- New USA Domestic / Asian / European vehicle coverage with multiple releases through the year.
- Frequent updates to the largest experienced based solutions available, already with more than 30 million specific fixes.
- Performance improvements, user interface, repair information and product enhancements included.
- Available Q4 2014 Battery Disconnect Procedures, Key fob and Remote Reprogramming.

See page 2 for more details

## What's New: SEMA, Instagram & Triple Speed

### We're going to SEMA and AAPEX!

Visit the Bosch Booth #30291 at the Specialty Equipment Manufacturers Association (SEMA) show, November 4-7 at the Las Vegas Convention Center. Or check out Bosch down the street at the Automotive Aftermarket Products Expo (AAPEX), Booth #5038, November 4-6 at the Sands Convention Center.

- Bosch, OTC and Robinair will debut new service tools and shop equipment in both booths
- Hang out with custom fabricator Bryan Fuller and 'Car Doctor' Ron Ananian at SEMA



We hope to see you there!

### Find OTC and Actron on Instagram!

We have joined the exciting world of Instagram! Are you there? Follow us at @OTCtools and @ActronTools for behind the scenes photos of our manufacturing plant, creative ways to use our products, contests and so much more!



OTC Instagram:  
<http://instagram.com/otctools>

Actron Instagram:  
<http://instagram.com/actrontools>

### OTC Triple Speed takes shape

The Triple Speed rolls on, with an all-new front end and leaning capability courtesy of Fuller Moto. See the latest build photos and video on Facebook.



Follow along on Facebook, Twitter and Instagram using #TripleSpeed.

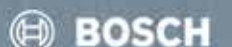



## Encore now with HD Software and Wireless TPMS\*

The first integrated diagnostics tablet for Android™ with fast startup and onboard battery has just released wireless TPR and Heavy-Duty software.\* Pair up with the optional 3834T OTC TPR TPMS Tool via Bluetooth®. The new 3895-07 Heavy-Duty Standard kit is available for reading DTCs and viewing live data on Class 4 – 8 vehicles.



Check out the Encore TPMS sensor registration process here.



3895-07



3834T

## Coming Soon: Battery Disconnect Procedures, Key fob and Remote Reprogramming!

Available for Encore October 2014

Available for Genisys Touch Q4 2014

The battery update covers Domestic and Import vehicles 2000 to present, with partial coverage for 1991-1999. Procedures include battery disconnection precautions, power windows, locks and sunroof reprogramming, engine and body control system resetting and more.

The key and remote programming update covers Domestic and Import vehicles 1996 to present, with partial coverage for 1993-1995. Procedures include system operation, unusual features, programming procedures, illustrated battery replacement procedures for remote and key transmitters and more.

## \$200 or \$325 REBATE On GENISYS EVO®



## PURCHASE A QUALIFYING GENISYS EVO AND RECEIVE A GIFT CARD

GENISYS EVO MODEL GIFT CARD VALUE  
3874, 3874HD, 3874TPR, 3874MVCI . . . . . \$325  
3875 . . . . . \$200

### HOW TO PARTICIPATE

1. REGISTER ON [WWW.BOSCHREBATES.COM](http://WWW.BOSCHREBATES.COM)
  2. PROVIDE A VALID SERIAL NUMBER
- Expires December 31, 2014.

## Genisys Touch™ Trade Up Promotion

Expires December 31, 2014

Replace your old professional scan tool\* with the Genisys Touch and choose from an OTC Tech Scope or OTC TPR Tool.

Details can be found at [www.otctools.com/promotions](http://www.otctools.com/promotions)  
Participate by visiting [www.boschrebates.com](http://www.boschrebates.com)

\*Code readers do not qualify.



3857 Tech Scope (value \$1,099)



3834T TPR (value \$459)

## Your one-stop shop for OEM tools

### Bosch Tech 2 \$700 Rebate

The only authentic General Motors Tech 2 scan tool with full, dealer-level diagnostics. Includes preloaded software that doesn't expire.

Visit [boschrebates.com](http://boschrebates.com)



F00E900977

Tech 2 Pro Optima

Expires December 31, 2014

### Bosch brings authentic OEM diagnostics to aftermarket again with Ford VCM II



F00E9016307HH

#### The Ford Vehicle Communication Module II (VCM II)

- Authentic OEM diagnostics for Ford, Lincoln and Mercury Vehicles.
- Customer Flight Recorder (CFR) functionality with an optional pendant cable.
- Four LED indicators and signaling device providing technician with continuous visual as well as audible operating status.
- Enhanced 802.11 wireless that minimizes dependencies on service department wireless capability infrastructure.

F00E9016297HH\*

Includes VCM II, VCM to Laptop cable, USB wireless cards, and DLC cable.

F00E9016307HH\*

Includes all contents of F00E9016297HH plus CFR kit.

\*Software license sold separately.

Ford and VCM II are used under license from Ford Motor Company.



F00K108322

#### GM MDI

- Authentic General Motors MDI vehicle communication interface (VCI) for wireless J2534 reprogramming and diagnostics.
- Requires software subscription to GM SPS (Service Programming System), which must be purchased separately via the ACDelco Tech Connect website.



F00E901631

#### Bosch Mastertech VCI

Validated J2534 Flashing – covers GM, Ford, Chrysler, Honda, Nissan, Mazda, Mitsubishi, Saab, BMW, and more to come. M-VCI is an OEM approved reprogramming device.

Authentic OEM Dealer Level Diagnostics\* – compatible with BMW ISTA, Saab GDS 2, GM Tech2Win, GM GDS 2, and more to come.

F00E901632 Bosch Mastertech VCI Aftermarket Diagnostic Software – Includes the final release of Shop Foremen Pro and ESI 2.0.

\* OEM dealer diagnostic software is purchased separately from vehicle OEM websites.

## Is your tool updated?

OTC has updated the Encore and Genisys Touch several times this year. If you haven't updated recently, you're missing new features, new vehicle coverage and major performance improvements.

### GENISYS TOUCH / ENCORE NEW COVERAGE IMPROVEMENTS

2014 subscription releases to date added:

- 29,276 new vehicle-ECU combinations
- 4,471 new systems
- 2,151 new Actuation type tests
- 416 new Adjustment type tests
- Over 500 new Manufacturer specific descriptions for OBD II Mode 6 parameters

New coverage added for 2014 Model Year GM, Ford, Chrysler/Jeep, Toyota, Mazda, BMW/Mini and Fiat vehicles with more on the way!

- Expanded coverage for Ford Battery Monitor System Reset for 2011-2013 vehicles
- Expanded ECU coverage for 2006-2013 Toyota/Lexus/Scion vehicles, including 4WD, Accessory Gateway, Electric Power Steering, Gateway, Immobilizer, Power Source Control, Smart Key, Theft Deterrent, Remote Engine Starter, Pre-collision and others

Enhanced coverage including Actuation and Adjustment tests have been added for Subaru 1999-2013, Jaguar 1997-2012 and Land Rover 2005-2012

- New coverage for Battery Replacement tests required on some Land Rover and Volvo vehicles after replacing the battery. More Battery Replacement tests coming soon!

New coverage for 1996 - 2012 Volkswagen/Audi and 2013 Honda, Hyundai, Kia, Mazda and Nissan

- New coverage for VW/Audi vehicle and system specific tests, such as DTC 01486 ESP Function Test for ABS, EPB Caliper Open and Close tests for Parking Brake (53) and Key FOB Matching for Central Convenience (46)

Expanded coverage for older Hyundai, Kia, Mercedes and BMW systems, including:

- New coverage for tests required when replacing the EHB module assembly on Mercedes Sensotronic Brake Systems, including EHB Brake Bleed, EHB Deactivate, EHB Activate, and Bosch exclusive procedure instructions

Updated repair information

- ABS Brake Bleed Procedures for all manufacturers
- Oil Light Reset procedures for all manufacturers
- Tune-up Specs for all manufacturers
- TSB References – GM, Ford, Chrysler, Jeep

3395

### Multimedia Interface Tester (MIT)

Stay Connected: Verify AUX, USB and Bluetooth connectivity

- Will pair via Bluetooth, Auxiliary or USB to vehicle to diagnose connectivity issues.
- Verify and diagnose customer complaints when connecting with infotainment systems.
- Provides a clean signal for accurate and reliable diagnostics.
- Works on Ford, GM and Hyundai vehicles.
- Includes a storage case that will accommodate the MIT and related adapters.



3880X

### OTC Automotive Inspection Camera

- Large 3.5" inch high resolution color screen for optimal viewing.
- Detachable 36" camera snake with position hold shaft.
- Images and video are recorded on the included SD card and can be viewed on the camera display or transferred to a computer.



## Genisys EVO® 2014 Software Available December 1

3421-149

### 2014 Super Bundle Kit

- Everything needed to update a Genisys EVO
- Includes 2014 Domestic/Asian, 2013 European, and preloaded System 5.0 memory card



3421-150

### 2014 Software Loyalty Kit

- Designed for customers who already have System 4.0 and newer.
- Includes 2014 Domestic/Asian and 2013 European



3421-151

### 2014 System 5.0

#### 4GB Memory Expansion Kit

- Pre-loaded with 2014 application software
- New applications require a separate purchase



## Nemisys 2014 Software Available December 1

3774-38

### OTC Nemisys 2014 Domestic/Asian software

OEM based 2014 Domestic and Asian coverage back to 1983 for engine, body, and chassis systems. Includes the Code-Assist™ Library of experienced-based Confirmed Fixes™ from Identifix® and Data / Sensor Info repair information.



## Encore/Genisys Touch HD



3895-07

### OTC Heavy-Duty Standard

- Class 4 - 8 Heavy Duty Standard truck Coverage
- Read / erase codes and view live engine data



3415

### OTC CAN Test Box

#### Breakout Box for Scan Tools

- Connects between Diagnostic Link Connector (DLC).
- Connect leads for increased diagnosis, analysis, and monitoring.

#### Useful Functions

- LEDs display signal detection
  - Flashing LEDs indicate ECU activity.
- Magnifies DLC
  - Allows monitoring of OBD II data lines.
- Monitors voltage
  - Displays battery voltage.
  - Alarm warning when voltage drops below 11.6v or rises above 15v.

## Heavy Duty Code Reader



3418

### OTC Heavy-Duty Code Reader

- Class 4 – 8 truck coverage.
- HD J1587 / J1708 and J1939 CAN, Engine, Transmission / ABS coverage and more for diagnostic trouble codes!
- Read and clear diagnostic trouble codes.
- Provides on screen DTC definitions or heavy-duty standard codes.
- Battery powered for off vehicle use.
- Internet update capable.

#### Applications:

Tow trucks, recreational vehicles, cement trucks, dump trucks, garbage trucks, buses, step vans, municipal vehicles, refrigerated trucks, and conventional trucks.

Heavy-Duty Standard compliant construction, marine, agriculture, & industrial diesel power plant configurations!

**Includes:** 9-Pin deutsch cable, 6-Pin deutsch cable, operations manual, 3-year warranty, and soft nylon carrying case.

## Tire Spoons



### Convex Slip Head

Unique "Convex Slip Head" curved design allows the spoon to slide easily into the tire bead while the spoon bump limits the depth for quick-and-easy operation.



### Grip grooves

Eliminate spoon slippage on the wheel rim while mounting or demounting the tire. The grooves also limit the depth of the spoon to help eliminate pinching tire tube applications.

5716	<b>HD Sliding Tire Spoon</b> 38" extends to 52", 3/4" diameter. Inner slide bar provides hammer action to easily insert and remove the spoon.	
5716G	<b>HD Sliding Tire Spoon with Grip Grooves</b> 38" extends to 52", 3/4" diameter. Inner slide bar provides hammer action to easily insert and remove the spoon.	
5720	<b>Sliding Dual Tire Spoon</b> 35" and 3/4" diameter. Unique configuration provides mount and demount heads on either end with the aid of a slide hammer mounted mid bar, allowing for hammering either end in or out of the tire bead. Twist-lock feature locks 3.5 lb. slide weight in position.	
5724	<b>Extending Tire Spoon</b> 22" extends to 34", 3/4" diameter. Twist-lock feature allows the spoon to be extended to any length and locked into position with a twist of the collar.	
5734-18	<b>Tire Machine Spoon, Double End, 18"</b> Has a curved end and a bent tip end for starting the bead on a tire changing machine.	
5734-18G	<b>Tire Machine Spoon, Double End with Grip Grooves, 18"</b> Has a curved end and a bent tip end for starting the bead on a tire changing machine.	
5735-18	<b>Double End Curved &amp; Flat Tip Curved Tire Spoon, 18"</b> Double end curved tire spoon. Handle knob enables easier spoon pick up. 3/4" diameter.	
5735-18G	<b>Double End Tire Spoon with Grip Grooves, 18"</b> Double end curved tire spoon. Handle knob enables easier spoon pick up. 3/4" diameter.	
5735-35	<b>Double End Curved &amp; Flat Tip Curved Tire Spoon, 35"</b> Double end curved tire spoon. Handle knob enables easier spoon pick up. 3/4" diameter.	
5735-35G	<b>Double End Tire Spoon with Grip Grooves, 35"</b> Double end curved tire spoon. Handle knob enables easier spoon pick up. 3/4" diameter.	
5735-42	<b>Double End Curved &amp; Flat Tip Curved Tire Spoon, 42"</b> Same great design as the original double end mount/demount tire spoon, but in a 42" length for added leverage. 3/4" diameter.	
5735-42K	<b>Double End Tire Spoon with Kick Start, 42"</b> Includes kick loops to allow the spoon to be forced into tight bead locations with the help of foot pressure. 3/4" diameter.	
5736-18	<b>Curved Tire Spoon, 18"</b> Handle knob enables easier spoon pick up. 3/4" diameter.	
5736-18G	<b>Curved Tire Spoon with Grip Grooves, 18"</b> Handle knob enables easier spoon pick up. 3/4" diameter.	
5736-24	<b>Curved Tire Spoon, 24"</b> Handle knob enables easier spoon pick up. 3/4" diameter.	
5736-24G	<b>Curved Tire Spoon with Grip Grooves, 24"</b> Handle knob enables easier spoon pick up. 3/4" diameter.	
5736-30	<b>Curved Tire Spoon, 30"</b> Handle knob enables easier spoon pick up. 3/4" diameter.	
5737-30	<b>Flat Tip Curved Tire Spoon, 30"</b> Handle knob enables easier spoon pick up. 3/4" diameter.	
5739-24	<b>Curved Shank Tire Spoon, 24"</b> The curved shank allows improved access for the spoon head around the tire bead or wheel rim. Handle knob enables easier spoon pick up. 3/4" diameter.	
5739-30	<b>Curved Shank Tire Spoon, 30"</b> The curved shank allows improved access for the spoon head around the tire bead or wheel rim. Handle knob enables easier spoon pick up. 3/4" diameter.	

## Scan Tool / Code Readers



3111PRO

### OTC Trilingual Scan Tool OBD II, CAN, ABS & Airbag

**Fix it Faster!** Expanded Domestic and Asian ABS & Airbag coverage. Now with over 4.3 million verified fixes at the touch of a button! Compatible with all 1996 and newer cars and light trucks.

#### Airbag (SRS) & ABS coverage:

1996-2010 GM, Ford and Chrysler  
1996-2009 Toyota, Honda, Hyundai and Nissan.

**Enhanced code request** For GM, Ford, Chrysler, Honda, Hyundai, Nissan and Toyota vehicles.

**Displays additional live engine data:** Now over 300+ possible PIDs. View engine RPMs, coolant temperature, Oxygen sensor readings and more!

**AutoID™** Automatically retrieves VIN from vehicle and decodes to Year/Make/Model.

**Component Locator** Text descriptions indicate where the vehicle component is located.

3108N

### OTC Pocketscan® Code Reader

- View LIVE engine data.
- Automatically reads DTC's.
- Erases DTCs.
- Reads and displays MIL status.
- Reads and displays I/M monitors.



3109N

### OTC Trilingual OBD II/EOBD and CAN Scan Tool

- AutoID™ automatically identifies most 2000 and newer vehicles.
- Graph live data.
- Read and erase diagnostic trouble codes.
- Read and display LIVE sensor data.
- Read and display freeze frame data.



## Battery



0684400732

### Bosch BAT 131 – Battery & Starting/Charging System Tester

The BAT 131 is the benchmark in battery testing, and is designed for testing all types of 6V and 12V starter batteries, including lead-acid, gel and fleece batteries/AGM. The rugged, exterior housing is specially designed to survive the harshest workshop conditions and molded perfectly for one-handed operation.

The load free test procedure provides fast, precise and reliable measurement results between 100 and 2000 CCA. In addition to CCA, the BAT 131 can also measure and display to CA, MCA, DIN, SAE, EN, IEC and JIS standards.

3183

### OTC Digital Battery Tester

Speed. Accuracy. Reliability. These are the cornerstones behind the technology in our digital battery testers. Test 12-volt batteries (125–1400 CCAs) and analyze by measuring multiple parameters within the battery to deliver accurate results. A live voltmeter allows easy starting/charging system testing. Its bright, 4-digit LED display indicates battery status, voltage, and available CCAs. It even compensates for cold temperatures.





### Pry Bars

#### 9900A

##### Persuader Pry Bar Merchansider

- 9900A is a merchansider specifically designed for the OTC 7168 30 inch Chisel and Alignment "Jimmy Bar".
- The merchansider is 52" high, 18" wide and 12" deep.

##### 7168 Jimmy Bar features:

- 10 - 30" in length; 7/8" Diameter.
- Forged and chromed Alloy Steel.
- Designed and heat treated to resist Bending and Breaking.
- Made in USA.
- Lifetime Warranty.

**NEW**



9900A

9901A

#### 9901A

##### MAJOR Persuaders Pry Bar Merchansider

- 9901A is a merchansider specifically designed for the biggest OTC chisel and alignment "Jimmy Bars"
- The merchansider is 64" high, 16" wide and 18" deep.

##### 7168, 7420 and 7421 Jimmy Bar features:

- 2 - 7168 Jimmy Bars (30" in length, 7/8" Diameter);
- 2 - 7420 Jimmy Bars (46" length, 7/8" Diameter);
- 1 - 7421 Jimmy Bar (54" length, 1" Diameter).
- Forged and Chrome Plated or Painted Alloy Steel.
- Designed and heat treated to resist bending and breaking
- Lifetime Warranty.

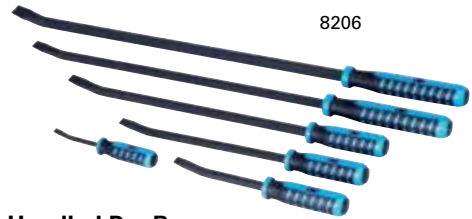

8206

##### Handled Pry Bars

- Heavy-duty pry bar made of tempered square steel.
- Black chrome striking cap allows hitting the bar without damage to the handle.
- Ergonomically designed dual durometer composite handle reduces hand fatigue.
- Polished tip with black oxide finish.
- Blue oxide finish resists rust and wear during use.
- OTC Marathon Lifetime Warranty.

**8203** - 3-piece handled pry bar set in gray molded tray. Includes 12", 18", and 24" sizes.

**8206** - 6-piece handled pry bar set in gray molded tray. Includes 8", 12", 18", 24", 32" and 36" sizes.

**8208** - 8" handled pry bar.

**8212** - 12" handled pry bar.

**8218** - 18" handled pry bar.

**8224** - 24" handled pry bar.

**8232** - 32" handled pry bar.

**8236** - 36" handled pry bar.



##### Jimmy Bars

We've forged these bars from chrome alloy steel, then heat-treated them to resist bending and breaking.

**7166** - 5/8" diameter, 18" long.

**7167** - 3/4" diameter, 24" long.

**7168** - 7/8" diameter, 30" long.

**7420** - 7/8" diameter, 46" long.

**7421** - 1" diameter, 54" long.



##### Rolling Head Pry Bars

You'll have a lot of leverage using one of these rolling head pry bars. The long, tapered body will also serve as an aligning drift.

**7162** - Pry bar; 6" long.

**7163** - Pry bar; 12" long.

**7164** - Pry bar; 16" long.

**7165** - Pry bar; 18" long.

### Pullers

#### PA7

##### 7-Ton Capacity Four-In-One™ Puller Set

- Quickly assemble a 2- or 3-jaw puller with standard 7-ton capacity. Maximum reach of 8-3/4" and maximum spread of 11" with long-reach arms.
- Ideal for hundreds of pulling jobs.



#### 7793

##### Master Bolt Grip Set (Grade 8)

- Multi-Purpose applications such as steering wheels, flywheels, harmonic balancers, pulleys and gears with tapped holes.
- Includes special stepped bolts for 1990-2005 GM 3300-3800 V6 crankshaft pulleys.



#### 4579

##### 9-Way Slide Hammer Puller Set

- Pulls flange-type rear axles and most front-wheel drive hubs.
- Internal and external jaws provide a variety of combinations to pull bearings, gears and seals.
- Two- and three-way cross blocks and cone provide the perfect jaw configuration for most jobs.
- Set also includes a grip wrench adapter and a dent puller attachment for sheet metal or other unique pulling requirements.
- Designed for use with other OTC 5/8"-18 thread slide hammer attachments.
- Packaged in blow-molded case.

##### OTC "GripLock" Pullers

- Manufactured to our rigorous specifications to ensure the quality professionals expect from OTC.
- Pressure bearing yoke cap holds jaws in place for ease of set up - in any orientation.
- 2 or 3 jaw application.
- Both external and internal pulling action.
- "Live Center" action forcing screw.
- Professional finished for long lasting durability.

**464** - Puller with a 4" maximum reach, 3" to 4" spread.

**465** - Puller with a 7" maximum reach, 3" to 7" spread.



#### 525

##### Flange-Type Puller Combination

- Two specialty pullers in one box: Flange-type puller and combination steering wheel, pulley and flywheel puller. Includes four sets of cap screws.
- Flange-type for removal of harmonic balancers, timing gears and other parts with two or three tapped holes.

### Fasteners

#### 5900A

##### Master TORX® Socket Set

- 52-piece, professional socket set in a blow-molded case.
- Hundreds of applications from front to rear on cars and trucks:
  - Seat belt bolts
  - Engine assemblies
  - Bumpers
  - Door strikers & latches
  - Truck box liners
  - Interior and exterior trim screws
  - Tail lamp lenses & assemblies
  - Headlight bezels
  - Brake rotor bolts
  - GM front-wheel drive front wheel bearings

- Styles available: TORX, TORX PLUS, tamper-resistant TORX and external TORX.
- Made from superior S2 steel to meet or exceed torque specifications.



5900A

##### TORX® Individual Socket Sets

**6100** - Standard TORX® Socket Set T10 - T60 (12 pc)

**6150** - External TORX® Socket Set (7 pc)

**6135** - Universal Brake Caliper Socket Set (9 pc)

**5905** - Tamper-Resistant TORX® PLUS Socket set (11 pc)

**6145** - Tamper-Resistant TORX® Socket set (7 pc)

**5931** - External Torx® PLUS Socket Set (8 pc)

**5942** - XZN Super Short Socket Bit Set (8 pc)

**6160** - Fraction Hex Socket Set (7 pc)

**6170** - Metric Hex Socket Set (7 pc)

**6180** - TORX® Plus Socket Set (9 pc)

6100

### Fuel Injection Tools

#### 7448A

##### Canister-type Fuel Injector Cleaner

Simply and completely clean a vehicle's fuel system with the 7448A Fuel Injector Cleaner.

With the addition of a quick-connect fitting, the removable hose can be thoroughly cleaned for storage and extending the life of the product. An included blowout fitting adapts to shop air supply to remove residual cleaner from hose lines.

The 7448A also includes our Fuel Injection Application Manual showing OE fuel pressure specs, fuel pump disconnect points, return line information and the adapter reference to OTC pressure adapter kits (6550PRO). Covers vehicles from 1997 through 2013.



Improved control valve

Ball valve when quick response is needed

Blow out fitting

Quick connect fitting for removable hose

**NEW**

Hose for gasoline and ethanol blends meets SAE standard 30R9



#### 6550

##### Master Fuel Injection Kit

Test fuel injection systems on most GMs, including GM TBI, Ford, Chrysler, and Jeep vehicles. Also works on imports, including CIS and CISE fuel systems.

- 0-100 PSI fuel pressure gauge.
- 35 of the popular OTC fuel injection adapters, each equipped with a quick-connect Schrader valve.
- '97 - '13 Fuel Injection Service Application Manual.
- Replacement seal kit also included.



#### 6550PRO

##### Pro Master Fuel Injection Service Kit

Covers 100% of vehicles sold in North America '97-'13.

Perform fuel pressure testing, diagnose weak fuel pumps or restricted filters, test for fuel flow and perform leak-down tests. Use to clean injectors and intake systems. Kit includes:

- 0 - 100 PSI Fuel Pressure Gauge.
- 47 of the popular OTC fuel injection adapters, each equipped with a quick-connect Schrader valve.
- '97 - '13 Fuel Injection Service Application Manual.
- Replacement seal kit also included.



#### 6550UPD

##### Professional Fuel Injection Update Kit

Upgrades existing 6550 Master Fuel Injection Service Kit into the 6550PRO. Kit includes:

- 12 OTC fuel injection system adapters each with a quick connect Schrader Valve.
- 1997 - 2013 Fuel Injection Service Application Manual.



#### 4480

##### Basic Fuel Injection Service Kit

- Performs running, residual, rail and flow rate pressure tests.
- Kit includes adapters, hoses and fittings to test fuel injection systems.
- Kit includes two popular adapters for import vehicles as well as the GM TBI adapter.
- Professional dual scale gauge reads 0-100 PSI and 0-700 kPa with relief valve, fuel discharge hose and rubber boot.
- Packaged in blow molded carrying case.



## Battery Tools



### 4639 Battery Terminal Service Kit (7 piece)

- Kit includes:
- 4611 – Battery terminal puller.
  - 4612 – 3-way battery post cleaner.
  - 4613 – Battery pliers.
  - 4614 – Side terminal battery wrench.
  - 4615 – Long-side terminal wrench.
  - 4616 – Battery terminal wrench - 10mm.
  - 4617 – Side terminal battery brush.



### 4631 Battery Terminal Service Kit (8 piece)

- Kit includes:
- 4611 – Battery terminal puller.
  - 4612 – 3-way battery post cleaner.
  - 4613 – Battery pliers.
  - 4614 – Side terminal battery wrench.
  - 4615 – Long-side terminal wrench.
  - 4616 – Battery terminal wrench - 10mm.
  - 4617 – Side terminal battery brush.
  - 4622 – Battery Cable Cutter.



### 4503 Double Flaring Tool Kit

- Designed for double or single flare in copper, aluminum, soft steel brake line, and brass tubing (to 45 degrees).
- Includes five adapters 3/16" through 1/2" (4.8 mm through 12.7 mm).
- Chrome swivel, made of alloy steel, reduces friction. Forged yoke made of heat-treated steel. Housed in a blow-molded storage case.



### 4504 Bubble (I.S.O.) Flaring Tool Kit

- Designed for crack-free bubble flares on soft steel tubing used in automotive brake systems.
- Includes four dies: 4.75, 6, 8, and 10 mm adapters.
- Forged steel yoke, flaring bar, and all the adapters needed for ISO bubble flaring.
- The most economical "Bubble" flare tool to date. Housed in a blow-molded storage.



### 6502 Master Brake Flaring Tool Kit

- Covers Single, Double, and Bubble type flares:
- Single Flare Standard Lines 3/16" – 1/2".
  - Single Flare Metric Lines 4mm – 14mm.
  - Double Flare Standard Lines 3/16" – 1/2".
  - Double Flare Metric Lines 4mm – 10mm.
  - Bubble Flare Standard Lines 3/16" – 1/2".
  - Bubble Flare Metric Lines 4.75mm – 10mm.
  - Kit contains flaring bar, arbor press, adapters, tube cutter, deburring tool, all in a hard case.

## Brake Service Tools



### 6596 Brake Pad Gauge

- The 6596 Brake Pad Gauge allows for a definitive measurement of brake pads to determine remaining life.
- Unique design allows for measurement on the vehicle without the removal of any components in most cases (wheel assembly or brake caliper).
- Quick reference of brake pad condition via color code scale.

Barrel Measurement	Quick Reference Color	Brake Pad Condition
8 mm or more	Green	No replacement necessary
3 mm to 8 mm	Yellow	Suggest replacement soon
0 mm to 3 mm	Red	Recommend replacement

### 6093 Disc Brake Pad Spreader

- Can be used on or off the vehicle during brake pad replacement to push the piston back into the caliper. Thick pushing plate (3/16") and wide, threaded collars are designed for heavy-duty applications.
- Works on single and dual piston calipers.
- Slotted plate design provides universal fit on dual piston caliper applications.

### 7034 Disc Brake Pad Spreader

- For use on all standard and four-piston caliper disc brakes.
- Retracts piston and holds pads snugly in place for easy assembly of caliper over rotor.
- An extremely rugged tool that's easy to use.

### 4743 Motorcycle Brake Caliper Spreader

- Compresses the brake pistons on most style calipers for easy pad replacement.
- Fits all front and some rear disc brakes.
- Range: .25" (5 mm) to 2.25" (58 mm). Works on all automotive applications in this range.



### 4799 Brake Piston Removal Locking Pliers

- This specially designed locking pliers allows the removal of brake caliper pistons during service or rebuild. The pliers is simply clamped into the I.D. of the caliper piston allowing it to be pulled out of the caliper. Range; 5/8" to 2-1/4" diameter pistons.

### 7661 Caliper Hanger Set

- Designed to hold brake calipers out of the way during brake, bearing, suspension or axle work, reducing possible brake hose damage.

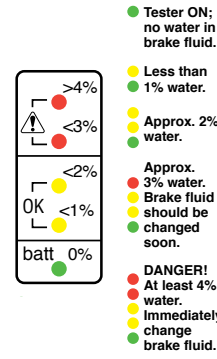

### Brake Fluid Tester

- Tester determines quality of brake fluid.
  - AAA battery included.
    - Remove cap from brake fluid reservoir.
    - Remove probe cap from brake fluid tester.
    - Press power button on top of tester. Green LED lights up.
    - Dip entire length of metal probes into brake fluid.
    - After one second, match color of LEDs with color chart to determine brake fluid quality.  - Tester automatically powers off after twelve seconds of inactivity.
- 4598-DOT3** – Tester calibrated with DOT 3 fluid.  
**4598-DOT4** – Tester calibrated with DOT 4 fluid.



NEW



### 8106 Master Cylinder Auto Filler

- Automatically fills brake fluid during bleeding.
- No more running reservoir empty.
- Saves time and money
- Eliminates spills onto paintwork.



### 8104 Vacuum Brake Bleeder

- This one man brake bleeding system allows for fast and efficient vacuum brake bleeding. Universal rubber fitting holds securely on brake bleeder screw. Attach shop air and use the quick release trigger for on-demand vacuum and hands free operation. Compact size and 17 oz. (500ml) capacity.

### 7317A Disc Park Brake Caliper Tool Kit

- Includes caliper piston adapter from 1-1/2" to 2-1/2" to service most Audi, Chrysler, Ford, GM, Honda, Jaguar, Mazda, Mitsubishi, Nissan, Saturn, Subaru, Toyota, VW, Volvo, Saab vehicles with 4 wheel disc brakes.



### 6703 Line Fluid Stopper Kit

- Stop messy fluid leaks and prevent contamination during service.
  - Kit seals all types of rubber and steel line found on fuel, brakes, AC, power steering and transmission system.
  - Includes two banjo style fitting stoppers, two steel line stoppers, six line plugs, a line disconnect tool, and a long reach line pinch-off tool for hard-to-reach hoses.
- 6703-1** – Banjo Line Fluid Stoppers, 2 pk.  
**6703-2** – Steel Line Fluid Stoppers, 2 pk.  
**6703-3** – Line Plug Fluid Stoppers, 6 pk.



### Fluid Evacuation / Brake Bleeding Tools

- Use to bleed brake systems and remove a variety of fluid from vehicles, such as antifreeze, oil, transmission fluid, gear lube, etc.
  - Quick connect locking hose adapters and ball-style on/off valve on hose prevent fluid leakage.
  - Equipped with a relief valve to prevent over-pressurizing the tank.
- 8100** – Operates by shop air or a hand pump; shipped complete with a brake bleeding hose, fluid evacuation hose, and two suction hoses (6 mm and 7 mm); 10-liter capacity tank.  
**8101** – Operates with shop air; shipped with a brake bleeding hose and fluid evacuation hose; 6-liter capacity tank.



### One-Man Brake Bleeder Hose

- Removes air from brake system, one wheel at a time, and eliminates the need for an assistant.
  - Hose easily attaches to bleeder screw, which holds hose in place and prevents leaking.
  - Check valve on end of hose prevents air from entering brake system when pumping brake pedal.
- 4599** – One-man brake bleeder hose, one only.  
**4809** – One-man brake bleeder hose, set of four. Do all the wheels at the same time. Includes four of the No. 4599.



### TCE 4230SFA

#### Bosch Swing Arm Tire Changer with Helper Assembly

- Swing arm tire changer designed for servicing standard and high performance tires.
- Services a large variety of tire sizes up to 44" in diameter.
- Includes helper system with 2 points of contact for challenging tire work.
- External clamping capacity up to 26" without the need for adapters.
- Features adjusted jaws with built in inflation.



The pneumatic following arm assists in mounting and demounting low profile tires.



Replaceable plastic inserts protect the rim surface from metal contact to prevent accidental damage.



Telescoping adjustments on the bead breaker shaft increase wheel width and tire diameter capacities.

(P/N 1695101608810 / 5pk)



### OCL 8850

#### Bosch On Car Brake Lathe

**Faster. Better. Stronger.**

Efficiently corrects lateral runout, DTV (disc thickness variation) and produces a superior finish versus competitive models.

- Standard adapters for 95% vehicle coverage in standard package.
- Delivers the industry's most accurate and precise results for finishing rotors.
- Bidirectional drive unit, eliminating the need to "flip" the lathe.
- Design saves time, eliminates need for full disassembly of brake system.
- Compact design fits in tight wheel wells.
- Mounts to the same machined surface as caliper.



## BL8992K

### Special 30th Anniversary Bundle

Includes:

- Brake Lathe 8922
- Bench
- 3-Jaw Chuck
- Micrometers

**MSRP \$7,995**

- Celebrating 30 years of the original Accu-turn single pass lathe that changed the industry
- Solid 470 lbs metal casting absorbs vibration for added rigidity
- Exceeds OE specifications with a "one pass" finish, regardless of the depth of cut
- Designed by a machinist for a true machine shop finish utilizing extra-large dovetail ways and adjustable gibbs
- Designed for maximum longevity and performance
- A must have in any shop performing brake jobs!
- Still made in the USA



### TCE 4435THP

#### Bosch High Performance Tire Changer

- Tabletop system with 24" internal and 22" external clamping.
- Ability to accommodate up to a 43" diameter assembly.
- 25% faster inflation system than benchmarked competition.
- 2 stage variable speed operation for fast operation and quick turnaround.
- Robust 5 1/2" x 5 1/2" automatic tilt tower with pneumatic lock.
- 40% increase in bead breaker power versus the previous model.
- 30% less mount/demount flexion versus benchmarked competitive offerings.
- 3 point helper system automatically maintains proper bead position for effortless orientation.
- Extreme structural rigidity for reduced flexion even for the most difficult UHP or RFT.
- 3 position adjustable bead breaker.
- Equipped with the TCE 320 Assist Assembly and bead breaker board to reduce operator effort on the toughest tire & wheel combinations.



Zeppa Bead Pressing Device (standard)  
(P/N 1695103261810)

## Shop Equipment



### 5300

#### OTC Stinger 3-Ton Jack Pack

- This jack pack includes a 3-ton service jack (5303) with lifting range of 5-3/4" to 18-1/2" and a pair of 3-ton jack stands (5372) with a base of 8-1/4" x 7-1/2" and height range of 12" to 17-11/16".

#### 2-1/4 - / 3-Ton Hydraulic Service Jacks

- Flanged upper body edge increases strength to resist twisting.
- Built-in safety overload system/ prevents use beyond their rated capacity.
- Rear swivel casters, for easy maneuvering and positioning.
- These jacks have 4" saddle dia., 21" overall reach, 6-1/2" frame height, 39-1/2" handle length, and a floor space of 13-1/2" x 24-1/2".

**5302** – 2-1/4-ton capacity with a lifting range of 5" to 18".

**5303** – 3-ton capacity with a lifting range of 5-3/4" to 18-1/2".



### 1780

#### OTC Stinger 22-Ton Capacity Jack Stands

- Height range is 13-7/8" to 19-7/8".
- Saddle size 3" x 3-3/4".
- Pin-style (non-ratchet) three positions, 3" intervals.
- Reinforced collar to meet newest ANSI PALD test standards.
- 11" flat base prevents sinking into the surface.



### OTC Stinger

#### 3-Ton, 6-Ton and 12-Ton Jack Stands

- Formed and welded steel base for strength; self-locking ratchet handle cannot be released under load. Durable baked enamel finish resists corrosion.
- Stands conform to ANSI PALD load rating standard; factory tested before shipment.

### 5372

- Pair of 3-ton jack stands.
- Base: 8-1/4" x 7-1/2".
- Height range: 12" to 17-11/16".

### 5373

- Pair of 6-ton jack stands.
- Base: 11-9/16" x 10-3/8".
- Height range: 15-5/8" to 23-11/16".

### 1784D

- Pair of 12-ton jack stands.
- Base: 12-1/8" x 10-7/8".
- Height range: 17-1/2" to 27-1/2".



### 4046

#### RamRunner two-stage hydraulic pump

RamRunner two-stage hydraulic pump with 3-position/4-way manual valve for double-acting rams, and a 6 ft. remote control cord. Supplied with one gallon and two quarts of oil.



### 5286

#### OTC Portable Diesel Particulate Filter Cleaner

- The advent of the 2010 Tier 4 cleaning requirements created the need for a lighter, more portable cleaning system which can be taken into the field to clean filters at the point of service.
- Lightweight and Highly Portable - ideal cleaning system for use in the shop or on a service truck.
- Flexibility - clean DPF's from 6" to 15.5" in diameter using shop or compressed air of at least 100 PSI.
- Fully Automated Operation - once started, the cleaning process can be completed unmonitored, freeing up technician to simultaneously do other work in the shop.
- Focused Air Jet Technology™ - concentrates a precise high pressure stream of air directly into every cell.
- Maximum Efficiency - OTC's unique floating puck prevents "splash back," which maximizes the volume of air entering each cell.
- Easy Maintenance - contains no internal filters that require user maintenance and its rugged design provides maximum durability.



4221



4235

#### Hydraulic Flow Testers

50 and 75 GPM hydraulic oil flow testers accurately measure oil flow, temperature, and pressures against manufacturers' specifications. Troubleshoot hydraulic circuits and isolate faulty components on mobile equipment, machine tools, fork lifts, agricultural and industrial tractors, and equipment (open or closed) hydraulic systems with capabilities up to 75 GPM at pressures to 5,000 PSI. Models include features such as an automatic pressure compensating load valve that lets you increase flow without affecting the pressure settings. Temperature flow and RPM readings are displayed in metric or English, and accurate to within plus or minus 2% of full scale. Each tester is protected by a safety disc, which ruptures automatically if pressures exceed the upper limits.

**4221** – 75 GPM hydraulic circuit tester. Comes with two pressure gauges and three 9-volt batteries.

**4235** – 50 GPM hydraulic circuit tester with single liquid-filled pressure gauge. Includes two adapter unions for 3/4" NPT fittings.

#### Bottle Jacks



No. 5221  
20-Ton

No. 5213  
12-Ton

No. 5213T  
12-Ton

- Base, pressure cylinder, and oil reservoir form one internal part, which results in a stronger jack.
- Piston never contacts cylinder, so pressure will be absorbed and not damage jack if vehicle tilts.
- The No. 5213T is telescopic, allowing for very low initial height with high lifting.

### 3095

#### Heavy-Duty Digital DEF Tester

Ensure the proper operation of Class 7-8 trucks utilizing the SCR system with accurate Diesel Exhaust Fluid solution displayed on screen.

- Digital Display
- Displays % UREA
- Displays washer fluid freeze point

The OTC 3095 makes testing a simple and quick process for an operator or technician.



### 5281

#### OTC DPF Thermal Processing Unit

- Designed to facilitate the cleaning of filters – with high amounts of wet soot, and unburned hydrocarbons.
- Pre-programmed thermal profile controls temperature 'ramp up' and 'cool down' to reduce the risk of cracking the DPF.
- Includes "pre-treat" cycle for oil-soaked filters.
- Holds temperature constant for two hours to ensure complete regeneration of filter.
- Built-in electronic safety lock prevents unauthorized opening of the door when temperatures exceed 200 degrees F.
- Large chamber accommodates various DPF sizes and shapes. Front access door allows for easy access to the thermal chamber.



### 4026

#### Air/Hydraulic Power Unit

- Heavy-duty aluminum body for durability and light weight.
- 10,000 PSI air/hydraulic pump.
- A perfect replacement pump for body and frame straightening equipment.
- Performs in either vertical or horizontal positions.
- Rotary-style pressure release provides superior operator control.





## Heavy Duty Equipment

**5105B**

### 1,100 lb. Capacity High-Lift Dual Wheel Dolly

- Effortless air-powered hydraulic lift system for a variety of applications.
- 0 to 42" lifting range.
- Six-inch lateral adjustment.
- Tilt adjustment of +15° to -8° ensures easy alignment.
- Features four swivel casters, two locking, for enhanced mobility.



**1770A**

### 1,500 lb. Dual Wheel Dolly

- Hydraulic jack provides almost 5" of lift and tilts wheel assembly 4° to prevent damage to wheel seal.
- Independent lifting rack provides maximum stability; rollers won't catch on load.
- Swivel casters for easy maneuverability.
- Floor space is 45" by 41".
- 6' chain holds load in place.
- Covered by OTC Lifetime Marathon Warranty®.



**5292**

### 27.5-Ton Capacity Under-Axle Jack

- Features class-leading 27.5 ton capacity.
- Robust design with completely sealed piston.
- New lever design and pneumatic release valve for more precise release control.
- Power return allows lowering with no load.
- Includes two height adapters for flexibility.
- PALD compliant.
- Minimum retracted height (with saddle only): 8-1/4".
- Maximum extended height (with screw extended and large adapter): 21-3/8".
- Stroke: 4.9375".
- PSI range: 90 to 175.



**5152**

### Mobile Vehicle Lift System (Includes two lifts)

- Mobile, tandem system is air-operated to handle your class 7 and 8 tractor lifting needs. No need to waste time re-blocking and making additional lifts for the clearance you need for under-vehicle service. Roll the system to the vehicle anywhere in the shop or outside on a level surface.
- Unique design provides lift from the tires, not the frame or axle members. Ideal for situations where limited ground clearance or a lack of clear access complicates lifting.
- Single controller operates both sides of the system for a smooth, level lift up to two full feet from the bottom of the tires to the ground. Units can double as support stands when retention pin is inserted.
- Covered by OTC Lifetime Marathon Warranty®.

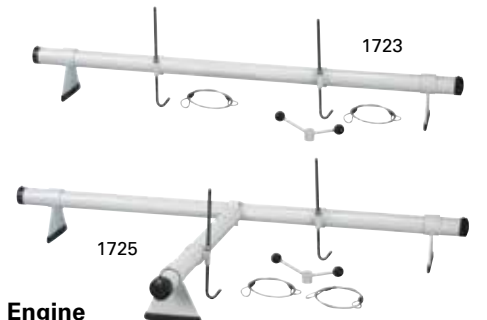

### Engine Support Bars

- Cutting edge, design self-centers load to prevent tipping on inclined surfaces.
- Smooth sliding legs adjust easily to different vehicle widths.
- PVC-coated support legs don't scratch vehicle surfaces.
- "Quick Connect" third-point bar (No. 1725) makes setup a snap.
- Spinner handle enables lightning fast adjustment.
- 1723** – Engine support bar (2-Point), 500 lb. capacity.
- 1725** – Engine support bar (3-Point), 700 lb. capacity.



### OTC Transfer Tanker

- Draining oil from a large displacement engine and getting it to your bulk storage container is a snap.
- Used oil is collected in the 15-gallon reservoir, and then rolls smoothly on 4" free-wheeling casters to your storage location.
- Pump moves five gallons a minute through the 8-foot transfer hose.
- Low profile, measures 7-1/2" from floor to top of reservoir.
- Can also be used for transferring antifreeze.

**5077** – Transfer Tanker equipped with an electric pump (No. 528093).

**5097** – Transfer Tanker equipped with a pneumatic pump (No. 529966).



**1572**

### Car Dolly (3,600 lbs., capacity pair)

- Innovative patent-pending design – clamps directly to pinch welds to prevent slippage during use.
- Independent units eliminate the need to adjust dolly width for different vehicle designs.
- Each unit has an independently adjustable threaded lift saddle with rubber pads to protect the vehicle frame.
- Universal design for use on all vehicle types without additional adapters.
- Provides easy movement of FWD vehicle after removal of drive train.
- The material on the 5" casters is polypropylene.
- Each unit has 1,800 lbs. capacity (3,600 lbs., pair) with low height of 9" and high of 14".
- May be used with or without tires on vehicle.



### 2- & 3-Ton Service Jack

- Ergonomic handle for user comfort & easy mobility.
- Foot pedal for quick approach of the lifting saddle to load. Built-in tray for fasteners and tools.
- CE certified, PALD compliant.
- Covered by OTC Lifetime Marathon Warranty®.

**5202** – 2-ton service jack. Min. height 3"; Max. height 18-1/4".

**5203** – 3-ton service jack. Min. height 5-1/2"; Max. height 20-1/2".



### 6- & 10-Ton Heavy-Duty Service Jack

- Ergonomic handle for user comfort & easy mobility.
- Foot pedal for quick approach of the lifting saddle to load. Built-in tray for fasteners and tools.
- CE certified, PALD compliant.
- Covered by OTC Lifetime Marathon Warranty®.

**5206** – 6-ton HD service jack. Min. height 6-11/16"; Max. height 22-13/16".

**5210** – 10-ton HD service jack. Min. height 6-11/16"; Max. height 23-13/16".



**1533**

### OTC Aluminum Racing Jack Pack

- **1532** – Jack lifts two tons and weighs only 43 lbs.
- Five pumps to max. height – 18".
- Low profile 3-1/2" makes it perfect for ground hugging, high performance cars.
- **1582** – 2-ton aluminum jack stands.
- 10-1/4" min. height, 15-1/4" max. height.
- Made from aircraft-grade aluminum.

### 25-Ton & 55-Ton Capacity Shop Presses

- Raise and lower bed easily on this tough, economical press that is ideal for pressing rear axle bearings, piston pins.
- Hand-operated winch and cable mechanism adjusts lower press bolster.

**1833** – 25-ton capacity press includes OTC No. 4002 handpump and 6-1/4" stroke ram.

**1850** – 55-ton capacity press includes OTC No. 4016 hand pump and 6-1/4" stroke ram.

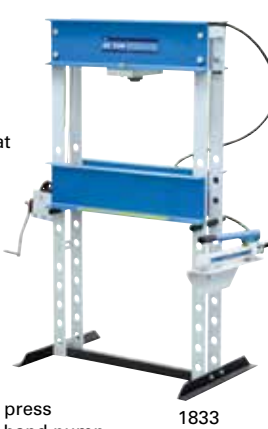

1833

### 6,000 lb. Capacity Heavy-Duty Mobile Floor Cranes

- Three boom positions for capacities of 4,000, 5,000, and 6,000 lbs for large engines and engines/transmissions combined.
- Usable reach of nearly 92".
- Boom swivels for vertical and lateral positioning.
- Legs extend to straddle extremely large tires.

**1814** – 6,000 lb capacity crane with electric/hydraulic pump and remote control.

**1813** – 6,000 lb capacity crane with two-speed hydraulic hand pump.



1814



### OTC Rear Suspension Bushing Tool

- Removes FAS II Airliner Freightliner Rear Suspension bushings in a fraction of the time of traditional methods.
- Saves on average 45 minutes per bushing (4 per vehicle) on flat rate of 1.5 hours per bushing.

**4244** – Freightliner Rear Suspension Tool.

**4245** – Freightliner Rear Suspension Tool – Master Kit includes 2510A Air/Hydraulic Pump.



**4295**

### Wheel Stud Service Kit

- Installation done by pushing on the head, eliminating the need for threaded adapters.
  - Reduces number of adapters required
  - Reduces damage to studs, hubs and bearings
  - Increases ease of use
- Remove and install 10 studs in only 10-15 minutes
- Can be powered with an impact wrench, no hydraulic power source required.
- No need to remove hub from vehicle.

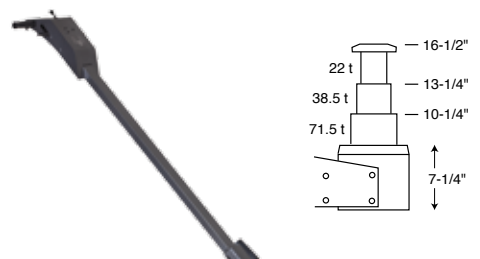

**5093B**

### 3-Stage Under-Axle Jack

- Three-stage lift capacity 20T, 35T, and 65-ton. Ideal for lifting loaded trailers, buses, and other Class 7 & 8 vehicles.
- Features a high load-approach speed.
- Air-driven cylinder with pressure control knob for maximum user safety.
- 4-position handle: horizontal, 45 degrees, vertical, or collapsed.
- 7-inch minimum height for low clearance vehicles.
- Comes with a 3-15/16 in. (100 mm) lifting extension.
- Complies with ASME / PALD test requirements.



**5130**

### OTC 1,000 lb. Capacity DriveMaster™ Driveline Lift

- Low profile of 7".
- Lift range: 23" to 30".
- Pivoting pump handle +/- 15° tilt in each direction.
- Includes 553516 differential mounting adapter. Mounts easily using existing bolt patterns. Fits the most common differentials currently in use on Category 7 and 8 Heavy Duty Trucks. Including: Eaton, Fuller, Rockwell, Meritor, Spicer, International, and Mack.
- CE certified, PALD compliant.

#### Optional adapter kits

- **558382** – Auxiliary box adapter.
- **561949** – Light duty transmission adapter.

### OTC Power Train Lift

- These lifts will handle engine and transmission assemblies, gas tanks, drive axle assemblies, engine/transaxle assemblies, electric bus batteries, and more.
- Scissors-type design allows access to all four sides of a component.
- Lifting and lowering motion controlled by hand-held remote.
- Table tilts ±15° side-to-side, or fore and aft.
- 20" x 32" tilt table.
- Larger casters accommodate heavy loads.

**5285** – 1,650 lb. Capacity Lift. Air / hydraulic operation – Foot control pump (2510A) with hose allows movement around lift. Minimum height is 29" with an 72" maximum height.



Covered by OTC Lifetime Marathon Warranty®.

**1585A**

### Power Train Lift 1,250 lb. Capacity

- For easy removal and installation of engine/transaxle assemblies on FWD vehicles. Also handy for pulling rear ends, leaf springs, and more.
- Includes 4020 air/hydraulic pump.
- Your shop air supply is the only thing you need to get the precise control offered by this OTC power train lift.
- Width between wooden support blocks is adjustable from 0-29". Load is secured with a tough nylon strap.

**1728**

### Air-Assisted 1,000 lb. Capacity High-Lift Transmission Jack

- Unique foot pedal design gives you complete control over the air-driven first stage to rapidly raise the mounting head to the transmission; second stage is hydraulically actuated – permitting precise operator control during removal and installation.
  - Transmission mounting head features four ratcheting brackets that adjust to fit a wide range of transmissions. Four-wheel base with locking swivel casters provides stability and portability.
  - Safety bypass prevents damage caused by a system overload.
  - Carries OTC Lifetime Marathon Warranty®.
- Specifications:**  
Min. height is 34-1/2" Max. height is 75"  
Max. forward tilt – 50° Max. backward tilt – 20°  
Max. side tilt (either side) – 10° Leg width – 41"



Head adjustable to 19-1/2" x 18".

**5100**

### Wheel Mate™

- Remove, install, rotate, & transport single tire-wheel assemblies.
- Internal ratcheting jack with 14 inches of vertical travel.
- Foot-operated wheel lock.
- U-shaped chassis that provides close, unhindered access to work area.
- Securely holds almost any truck wheel, including wide-based singles, without restraining chains.
- Heavy-duty ball-bearing wheels swivel casters for maximum maneuverability.





# MUSCLETOOLS

## Robinair A/C Tools & Equipment

**92500**

### Transmission Fluid Exchanger

You can have the vehicle in and out of the service bay in less than 20 minutes!

Our unique approach to exchanging fluid... through the transmission oil dipstick!

- No rusty fittings to break loose.
- Easy, convenient, and no damage to other engine components.
- Exchange oil in the pan before it passes through the transmission filter.
- It cannot be hooked up backwards.

Operate through dipstick only, cooler line or a combination of the two!

- Exchange accuracy approx. +/- 1/4 qt.
- 32-qt. supply tank; 34-qt. waste tank.
- Works with all types of automatic transmission fluid.
- Unprecedented one-tenth quart flow metering for adding or subtracting fluid from the pan.
- Complete set of adapters for most foreign and domestic vehicles.



**75700**

### Coolant Exchanger

- Our 10 minute exchange process means no more waiting for the engine to warm up!
- Our "engine Off" feature removes pulleys, belts, and fan blades from the safety equation.
- Vacuum mode creates a "push/pull" exchange process allowing the technician to safely remove high pressure in a hot system.
- Leak check feature allows the technician to test for leaks prior to refilling.
- Two clearly marked valves and an easy-to-read gauge make this machine very easy to use.
- No electricity required. 90 psi shop air drives the exchange process, as well as the 2 gpm pump on the waste tank.
- Two external new coolant supply tanks allow on-board storage of two different coolant types.



**TIF7610**

### IR Thermometer PRO

- SoC (System-on-a-Chip) Technology - Complete IR design incorporated on a single chip, creating compact and lightweight design.
- Innovative optical lens - high accuracy measurements over wide temperature ranges. 10:1 distance to spot (D:S) ratios available.
- Laser pointer - Simply point at desired target and press the trigger for temperature reading.
- High/low pass filters with audible alarms for out of range measurements.
- Temperature modes - Maximum (MAX).



### Refrigerant Tanks

**17121** - 30 lb. tank, 1/4" fittings (25150, 25175, 25200B, 34234, 34300-2K, 34800 series).

**17506** - 50 lb. tank, 1/4" fittings (17800A, 17800-2K, 17700A, 25150, 25175, 25200B series).



**34788**



**34788-H**



### AC Service

- Fully-Automatic Function: Program to recover, vacuum, leak test and charge without operating panel valves.
- Oil Inject: Automatically inject oil back into the vehicle A/C systems.
- Refrigerant & Oil Database: A/C system capacities for North American market vehicles.
- Indicator light and notification alarm: Notifies the user when service is complete, or if a problem has occurred.
- Vacuum Leak Test: Monitors level after evacuation, informs of possible leak.
- Automatic Air Purge: Eliminates damaging air without monitoring gauges or opening valves.
- Automatic Refrigerant Refill: Maintains a user-selectable amount of refrigerant in an internal vessel and signals with it's time to change supply tank, no monitoring required.
- Vacuum Feature: Defaults to 15 mins, programmable up to 99 mins. "Remaining time" is displayed.
- Refrigerant Charging: Select a charge mode from high or low side.
- Refrigerant Management System: Displays refrigerant use and monitors remaining filter life. Prompts appear when 1/3 of filter life remains.

**34788** - A/C Recover, Recycle, Recharge Machine.

**34788-H** - A/C Recover, Recycle, Recharge Machine - Hybrid and Non-Hybrid V.

- Capable of servicing high voltage electric compressor A/C systems.

**75240**

### Coolant and Battery Refratorometer

Coolant scale range: 32° F/0° C to -60° F/ -51° C.



### Econo-Clean Coolant Service Accessories

**75134** - Coolant test strips.

**75234** - 3-way heavy-duty truck coolant test strips.



### UV Leak Detection Kits

- The easiest and most accurate gun available today.
- No guesswork - a pre-measured application every time.
- One squeeze injects a pre-measure amount (1/8 oz.) of dye. No more adding too much dye.



### Multi-Purpose and Coolant Fluorescent Dye

**MULTI-PURPOSE** (engine oil, transmission) 16244, 16245

**COOLANT** 16885, 16890



**16244**  
6 applications

**16885**  
6 applications

**16890**  
32 applications

**16245**  
32 applications

**16009**

### DiscovR Refrigerant Identifier

- Fast and Accurate. "Pass" and "Fail" lights clearly show if refrigerant is pure enough to be recovered.

#### Product Specifications:

Refrigerant: R134a  
Input Power: 12 VDC  
Accuracy: Pass/Fail - 95% pure R134a  
Air Detection: Yes  
Approvals: SAE J1771, UL/C



**TIFZX**

### Heated Pentode® Refrigerant Detector

- Heated Pentode® sensor technology
- Tri-color visual leak size indicator
- Detects all CFC, HFC, HCFC's including R-12, R-22, R-123, R-134a, R-404a, R-407a, R-408a, and R-410a.



**22791**

### InfraRed Refrigerant Leak Detector

- Advanced infrared sensor designed to last a minimum of 10 years.
- Three sensitivity levels down to 0.15 oz./year.
- Automatically recalibrates in highly contaminated areas to help pinpoint the exact location of the leak
- Won't trigger on oil or moisture.



## Robinair Manifolds

### 2-Way Brass Manifold



**44150**  
Dual R12/134a Kit

**45111**  
R134a Manifold Hose Kit

### 2-Way Aluminum Manifold



**48510** R134A  
• 90° Manual couplers  
• 72" R134a Hose Set (1/2" ACME x 14mm)

**47150** Dual R12/134A  
• 90° Manual couplers  
• 72" R134a Hosea Set (1/2" ACME x 14mm)  
• 72" R12 Hose Set (1/2" ACME x 1/4" MFL)

### Economy Manifolds



**48134A**  
R134 brass manifold, hose set and service couplers

**49134A**  
R134 aluminum manifold, hose set and service couplers

### A/C Fluorescent Dye



**16240**  
64 applications  
One 8 oz. bottle

**16241**  
64 applications  
One 8 oz. bottle

**16242**  
12 applications  
Twelve 1/4 oz. bottles

**16243**  
24 applications  
Six 1 oz. bottles

**TIF9010A**

### Slimline Programmable Scale

- Completely portable refrigerant scale, battery powered, can be used with all refrigerants.
- Extreme accuracy.
- 110 lb./50 kg capacity.



## Robinair Vacuum Pumps

### VacuMaster® Single Stage Vacuum Pumps

- 15115** - 1.5 CFM Vacuum Pump.
- 15310** - 3 CFM Vacuum Pump.
- 15510** - 5 CFM Vacuum Pump.



### VacuMaster® 2-Stage Vacuum Pumps

- 15150** - 1.5 CFM Vacuum Pump.
- 15300** - 3 CFM Vacuum Pump.
- 15500** - 5 CFM Vacuum Pump.



### CoolTech® Vacuum Pumps

- 15434** - 4 CFM Vacuum Pump.
- 15600** - 6 CFM Vacuum Pump.



Not responsible for errors in description. / 14-120 Q4 2014 Edition, Printed in U.S.A.