

MUSCLE TOOLS

Electronic Diagnostics | Special Tools | Shop Equipment | A/C Tools

Q1 2015 Edition



Tis the season for service

Colder weather means major service opportunities, including:

- Suspension
- Battery testing/replacement
- Collision repair
- Light-duty diagnostics of heating/cooling systems
- Heavy-duty diagnostics
- Brakes/undercar service

You can find tools and equipment for all the above from Bosch, OTC and Robinair at upcoming industry shows HDAW, TMC, NADA and AutoMechanika Chicago, as well as your local distributor.



New for 2015: unmatched 98.5% recovery

NEW

Robinair introduces its next innovation, the 34788NI and 34788NI-H, featuring an industry-leading 98.5% recovery efficiency for standard and hybrid vehicles and fully automatic function.

See page 8



THE HEAVY-DUTY TOOL: 3824 BOSCH ESI[truck]

The most complete diagnostic coverage for multibrand heavy-duty trucks and engines, performing special tests and parameter reset capabilities. Use one tool to test, troubleshoot and see repair information. Diagnose vehicle, engine, transmission and brake problems.

RUGGEDIZED OE-LEVEL DIAGNOSTICS PC TABLET

Featuring Windows® 7 operating system that supports multitasking & separate RP1210 Communication Device.

ADDITIONAL COVERAGE

Trailer ABS Controllers; Allison & Eaton Transmissions.

THE MOST COMPLETE HD DIAGNOSTIC COVERAGE

Trucks: Freightliner, International, Kenworth, Mack, Volvo, Peterbilt, Sterling, Westernstar, MD Trucks (Freightliner Sprinter Van, Isuzu, GM and Ford).

ENGINE COVERAGE

Heavy-duty engines – Caterpillar, Cummins, Detroit Diesel-MBE, Deutz, Mack, MTU, Navistar, PACCAR, Perkins and Volvo. Medium and light duty engine software included.

HEAVY & MEDIUM DUTY FUNCTIONS

Read and clear codes, calibrations, diagnostics, track service schedules, data stream, component technical data, actuations and tests, wiring diagrams, system data, repair reports, parameter settings and repair information. Also includes OBD scan for pick-up trucks.



3824 WINDOWS 7 TABLET SCAN TOOL
Includes VCI, 6 pin and 9 pin cables

3824BSC SCAN KIT
• Use with your shop PC
• Includes Bosch diagnostic software, VCI, 6 and 9 pin cables.

OBD II TPMS TOOL WITH ACTIVATION, DIAGNOSTIC & RELEARN CAPABILITIES

3838 OBD II TPMS Tool

Save time and perform additional diagnostic capabilities during tire service tire rotations, tire sensor evaluations and reset procedures. The OTC 3838 is both a sensor activation and diagnostic device that features a wireless OBD II module for TPMS sensor registration. The tool works with all OEM and aftermarket sensors.

- Large 3.5" color display featuring easy-to-read icons
- Wireless communication between handset and OBD II module
- SD card for recent vehicle storage
- USB for software updates
- RJ 45 connection capability
- Includes battery charger



About TPMS

All 2008 and newer automobiles and light trucks on the road today have TPMS sensors that must be reprogrammed every time tires/wheels are replaced or rotated. If the TPMS sensors are not reprogrammed, the system will continue to report information that could be incorrect such as tire pressure and position of the wheel. TPMS sensors provide data such as sensor identification; tire pressure, temperature and sensor battery life.

AVAILABLE FEBRUARY

RECEIVE A 1-YEAR TOOLGUARD EXTENDED SERVICE CONTRACT

WHEN YOU BUY A 5280 DIESEL PARTICULATE FILTER CLEANER

Toolguard Extended Service

5280

Promotional offer includes an additional year of warranty at no charge, a \$1,550.00 value! The ToolGuard™ Extended Service Contract will continue to provide on-site service* for a total of two years.

ToolGuard™
EXTENDED SERVICE CONTRACT

Toolguard Extended Service available in US only.



How to participate/redeem

Register product at register.servicesolutionsportal.com within 30 days of purchase to qualify for the extended service. Upon receipt, an email will be sent with the FREE Toolguard Service Contract.

* Filters and maintenance items are not included with the ToolGuard™ Extended Service Contract. Additional terms and conditions apply. Details available upon request or during product registration.

✓ END-USER PROMOTION
✓ \$1,550 VALUE

See page 6

\$200 Rebate on Genisys Touch™



3895

The latest updates include

- 2014 USA Domestic / Asian / European vehicle coverage with multiple releases through the year.
- Frequent updates to the largest experienced-based solutions available, already with more than 30 million specific fixes.
- Performance improvements, user interface, repair information and product enhancements included.
- Battery Disconnect Procedures, Key fob and Remote Reprogramming.

How to participate/redeem

Visit boschrebates.com

Receive ESI 2.0 Software kit * when you purchase a Bosch Mastertech VCI

Advantages of Software:

- Quick module status check of the vehicle network.
- Wide range of functions such as: Auto Brake Bleed Test and Maintenance Light Reset.
- Vehicle health check with complete mode 6 coverage.
- OE level bi-directional controls for engine, body and chassis systems.
- Includes European, Asian, and Domestic coverage.



F00E901631

F00E901632

Visit www.boschrebates.com to participate

FREE software. \$500 Value

* Includes the final release of Shop Foremen Pro and ESI 2.0. The 2013 final release software is a one-time purchase license (no future updates).

See page 2

Exceptional Tire Changer Closeout Pricing!

Customer Savings



TCE4230
Closeout Pricing Plus Rebate \$500
Up to a \$1,400 Value

While Supplies Last



TCE4230SFA
Closeout Pricing Plus Rebate \$500
Up to a \$1,400 Value

While Supplies Last



TCE4335THP
Closeout Pricing Plus Rebate \$650
Up to a \$1,650 Value

See page 6

Other Wheel Service Rebates

Gift Card Rebates:

\$500 WBE 4230
\$1,500 FWA 4437
\$1,500 FWA 4630



Visit www.Boschrebates.com to redeem. Available in US and Canada.

Extended to March. 31, 2015

OTC

ROBINAIR

actron

BOSCH

Encore now with HD Software and Wireless TPMS*

The first integrated diagnostics tablet for Android™ with fast startup and onboard battery has just released wireless TPR and Heavy-Duty software.* Pair up with the optional 3834T OTC TPR TPMS Tool via Bluetooth®. The new 3895-07 Heavy-Duty Standard kit is available for reading DTCs and viewing live data on Class 4 – 8 vehicles.



3893



3895-07



3834T

Check out the Encore TPMS sensor registration process here.



Battery Disconnect Procedures, Key FOB and Remote Reprogramming!

The battery update covers Domestic and Import vehicles 2000 to present, with partial coverage for 1991-1999. Procedures include battery disconnection precautions, power windows, locks and sunroof reprogramming, engine and body control system resetting and more. The key and remote programming update covers Domestic and Import vehicles 1996 to present, with partial coverage for 1993-1995. Procedures include system operation, unusual features, programming procedures, illustrated battery replacement procedures for remote and key transmitters and more.

Battery Service Tools

Test battery voltage and CCA in less than 10 seconds

Quickly test charging and starting system health without disconnecting leads

- Download the OTC3200 app from the Google Play or iTunes store. View battery test data by scanning the device QR code*. Instructions included on testing device.
- All light duty applications - test 6V, 8V and 12V lead acid and AGM batteries
- Diagnose bad batteries faster – an internal 9V battery allows testing for deeply discharged batteries
- Share your test results – print, save or email a customer friendly color report
- Confidently recommend repairs – use your smart phone or tablet camera to embed photos into customer reports
- Sync feature sends information to all phones used in your shop so every tech can access reports by vehicle.

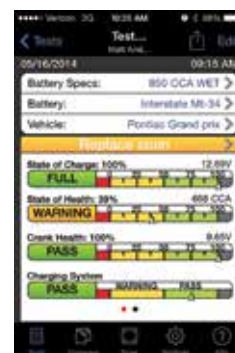

Customer Friendly Report



Technician Detail Report



Watch the tool used at a local shop on a 2000 Celica here:



3200

*Smart devices paired with the tester must have auto-focusing rear-facing camera to meet full requirements

Your one-stop shop for OEM tools

Tech 2 Pro Optima

The only authentic General Motors Tech 2 scan tool with full, dealer-level diagnostics. Includes preloaded software that doesn't expire.

Visit boschrebates.com

F00E9009777HH



Bosch brings authentic OEM diagnostics to aftermarket again with Ford VCM II



F00E9016307HH

The Ford Vehicle Communication Module II (VCM II)

- Authentic OEM diagnostics for Ford, Lincoln and Mercury Vehicles.
- Customer Flight Recorder (CFR) functionality with an optional pendant cable.
- Four LED indicators and signaling device providing technician with continuous visual as well as audible operating status.
- Enhanced 802.11 wireless that minimizes dependencies on service department wireless capability infrastructure.

F00E9016297HH*

Includes VCM II, VCM to Laptop cable, USB wireless cards, and DLC cable.

F00E9016307HH*

Includes all contents of F00E9016297HH plus CFR kit.

*Software license sold separately.

Ford and VCM II are used under license from Ford Motor Company.



F00K10832235E

GM MDI

- Authentic General Motors MDI vehicle communication interface (VCI) for wireless J2534 reprogramming and diagnostics.
- Requires software subscription to GM SPS (Service Programming System), which must be purchased separately via the ACDelco Tech Connect website.



FREE software. \$500 Value

F00E901631

Bosch Mastertech VCI

Validated J2534 Flashing – covers GM, Ford, Chrysler, Honda, Nissan, Mazda, Mitsubishi, Saab, BMW, and more to come. M-VCI is an OEM approved reprogramming device.

Authentic OEM Dealer Level Diagnostics* – compatible with BMW ISTA, Saab GDS 2, GM Tech2Win, GM GDS 2, and more to come.

F00E901632 Bosch Mastertech VCI Aftermarket Diagnostic Software – Includes the final release of Shop Foremen Pro and ESI 2.0.

* OEM dealer diagnostic software is purchased separately from vehicle OEM websites.

3395

Multimedia Interface Tester (MIT)

Stay Connected: Verify AUX, USB and Bluetooth connectivity

- Will pair via Bluetooth, Auxiliary or USB to vehicle to diagnose connectivity issues.
- Verify and diagnose customer complaints when connecting with infotainment systems.
- Provides a clean signal for accurate and reliable diagnostics.
- Works on Ford, GM and Hyundai vehicles.
- Includes a storage case that will accommodate the MIT and related adapters.



NEW



3880X

OTC Automotive Inspection Camera

- Large 3.5" high resolution color screen for optimal viewing.
- Detachable 36" camera snake with position hold shaft.
- Images and video are recorded on the included SD card and can be viewed on the camera display or transferred to a computer.



3167

Battery & Electrical System Diagnostic Tester

- Digital circuitry precisely controls battery test loads to accurately determine battery conditions.
- Tests both flooded lead acid and AGM/gell cell batteries accurately – down to 1 volt state of charge.
- Tests vehicle starting and charging systems with minimal user interaction.
- Tests all 6- & 12-volt batteries with a 50-2000 CCA operating range.
- Scales: CCA, CA, AHR, MCA, JIS, DIN.
- Removable/auto-sensing leads. (3' leads included in kits, optional 10' leads available.)
- Optional amp clamps for current drain tests and starting/charging measurements.
- Includes SABRE HP, 3' test leads, side-post terminal adapters, instruction manual, and molded-plastic carrying case.

3180

100 Amp Battery Load Tester

- 100 amp load capacity.
- 0 - 16 volt range.
- Load safety switch prevents arcing.
- Works on both 6V and 12V batteries.
- Ceramic insulators.



3181

130 Amp Heavy-Duty Battery Load Tester

- 130 amp load capacity for accurate results.
- 0 - 16 volt range.
- Uniquely-designed clamps for both top and side post batteries.
- Large display with zero adjust.
- Works on both 6V and 12V batteries.



3183

OTC Digital Battery Tester

Speed. Accuracy. Reliability. These are the cornerstones behind the technology in our digital battery testers. Test 12-volt batteries (125-1400 CCAs) and analyze by measuring multiple parameters within the battery to deliver accurate results. A live voltmeter allows easy starting/charging system testing. Its bright, 4-digit LED display indicates battery status, voltage, and available CCAs. It even compensates for cold temperatures.



0684400732HH

Bosch BAT 131 Battery & Starting Charging System Tester

The BAT 131 is the benchmark in battery testing, and is designed for testing all types of 6V and 12V starter batteries, including lead-acid, gel and fleece batteries/AGM. The rugged, exterior housing is specially designed to survive the harshest workshop conditions and molded perfectly for one-handed operation.



The load free test procedure provides fast, precise and reliable measurement results between 100 and 2000 CCA. In addition to CCA, the BAT 131 can also measure and display to CA, MCA, DIN, SAE, EN, IEC and JIS standards.



4639

Battery Terminal Service Kit

This kit includes seven favorite battery tools, housed in a rugged, vinyl-coated fabric pouch. Kit includes: a heavy-duty battery terminal puller, 4-way battery post cleaner and reamer, angled battery nut pliers, GM 5/16" battery terminal ratchet wrench, extra long 5/16" terminal ratchet wrench, 10 mm battery terminal ratchet wrench, and side terminal battery brush.

OTC Leak Tamer 30-Day Satisfaction Guarantee

It's a straight-forward guarantee. Try it for 30 days and if you're not completely satisfied, return it to your participating authorized dealer for a full refund.

6522

OTC EVAP – Leak Detection System

- Pinpoint leaks with Smoke and dye
 - UltraTraceUV® dye deposits at exact location of a leak
 - Finds leaks that smoke alone won't find
 - It's the only OEM-Approved dye solution
- Compact light weight design
 - More powerful diagnostics in smaller package



Genisys EVO® 2014 Software

3421-149

2014 Super Bundle Kit

- Everything needed to update a Genisys EVO
- Includes 2014 Domestic/Asian, 2013 European, and preloaded System 5.0 memory card



3421-150

2014 Software Loyalty Kit

- Designed for customers who already have System 4.0 and newer.
- Includes 2014 Domestic/Asian and 2013 European



3421-151

2014 System 5.0

4GB Memory Expansion Kit

- Pre-loaded with 2014 application software
- New applications require a separate purchase



Nemisys 2014 Software

3774-38

OTC Nemisys 2014 Domestic/Asian software

OEM based 2014 Domestic and Asian coverage back to 1983 for engine, body, and chassis systems. Includes the Code-Assist™ Library of experienced-based Confirmed Fixes™ from Identifix® and Data / Sensor Info repair information.



Encore/Genisys Touch HD



3895-07

OTC Heavy-Duty Standard

- Class 4 - 8 Heavy Duty Standard truck Coverage
- Read / erase codes and view live engine data

3895-08

OTC Genisys Touch 12 Month Software Subscription

Genisys Touch Domestic, Asian and European Software 12 month subscription kit provides a year of frequent and valuable updates for new coverage, coverage enhancements, repair information and application improvements.



3834T

OTC TPR Activation Tool

The OTC's TPR is a fast and simple to use stand alone TPMS activation tool!

- Lower cost kit for use with the Genisys Touch scan tool or as a stand alone tool.
- Works on vehicle TPMS sensors through 2013.
- Bright graphic display and simple navigation buttons enable vehicle selection for fast activation.
- Automatically adjusts activation output power to eliminate cross activation of near sensors.
- Tool includes a 6 month update subscription from www.tpmsupdates.com



3415

OTC CAN Test Box Breakout Box for Scan Tools

- Connects between Diagnostic Link Connector (DLC).
- Connect leads for increased diagnosis, analysis, and monitoring.

Useful Functions

- LEDs display signal detection
 - Flashing LEDs indicate ECU activity.
- Magnifies DLC
 - Allows monitoring of OBD II data lines.
- Monitors voltage
 - Displays battery voltage.
 - Alarm warning when voltage drops below 11.6v or rises above 15v.

3076

OTC HD Scan with Ez-Tap

- In-shop wireless capability.
- Ez-Tap Wireless Vehicle Communication Interface (VCI) works with OEM diagnostic software.
- One wireless VCI for all your diagnostic software.
- Eliminate cables and cable replacement costs.



Steering Service Tools



6496

Pitman Arm Puller

- Cuts Removal Time from 31/2 Hours to 40 Minutes!
- Labor intensive removal of steering sector not necessary.
- Compact design allows easy access to the Pitman arm.
- Works on most domestic SUVs and pickups.
- Live center on forcing screw and use of a standard wrench results in less effort required.
- Tool is forged steel for durability and long life.



6299

Separator Set (5 piece)

- Features five popular "pickle forks" in a blow-molded case.
 - Used to remove shock linkage, tie rods, and ball joints. Also for general service on many cars and light trucks.
- Includes:
- 6531 – Size 11" x 1-1/8" Fork Spread.
 - 6532 – Size 11-3/4" x 1-5/8" Fork Spread.
 - 6533 – Size 11-5/8" x 1-7/16" Fork Spread.
 - 6534 – Size 16" x 11/16" Fork Spread.
 - 6535 – Size 16" x 15/16" Fork Spread.

7832

GM Torsion Bar Unloader

- Required to safely release the tension on the front suspension torsion bar to service the front suspension.
- Larger design to cover the newer GM truck applications.
- Application: 2011 & newer HD C/K trucks.



6497

Super-Duty Pitman Arm Puller

- Works on 2005 and newer Ford F-250 and F-350 four-wheel-drive Super Duty trucks.
- Allows the Pitman arm to be removed from the steering gear while the steering gear is still in the vehicle.
- Two clamp bolts lock the jaws on the Pitman arm, ensuring a solid grip.
- Maximum jaw spread is 3-1/4".



6939

Broken Bolt Extractor Tool

- Remove frozen, broken or cut off bolts within steering or suspension bushings.
- Can also be used to remove and install wheel studs and other general pressing needs.



6939-1

Broken Bolt Extractor Adapter Set

Available for use with the 7248 C-Frame.



6295

Front End Service Set

- Kit includes five popular tools used for servicing Pitman arms, ball joints, and tie rods on most vehicles.

Set includes:

- 7314A – Pitman arm puller.
- 7315A – Tie rod end remover.
- 7503 – Outer tie rod remover/ball joint separator.
- 6296 – Pitman arm/tie rod end puller.
- 6297 – Ball joint separator.



Ford Axle Shaft Seal Installers

Correctly installs the seal onto the axle shaft and into the wheel knuckle, preventing front hub vacuum leaks that would cause the 4WD to not engage.

6695

Ford Axle Shaft Seal Installer. Works on 1998-2004 Ford F-250, F-350, F-450, and F-550 4X4s having the vacuum-operated front axle.

6697

Ford Axle Shaft Seal Installer. Works on 2005-newer Ford F-250, F-350, 4X4s having the vacuum-operated front axle.

6698

Ford Axle Shaft Seal Installer. Works on 2005-newer Ford F-450, F-550, 4X4s having the vacuum-operated front axle.

6275

Tie Rod/Pitman Arm Adjusting Set

These tools have a unique design that permits 360° rotation of the adjusting sleeve, even where space is limited.

Accommodates 1/2" drive ratchet or breaker bar.

Set consists of:

- 7095 – 3/4" diameter adjusting sleeves.
- 7096 – 7/8" diameter adjusting sleeves.
- 7097 – 1-1/8" diameter adjusting sleeves.
- 6274 – 1-13/16" diameter adjusting sleeves.
- 6084 – 1-7/16" dia. adjusting sleeves.

4559

Manual / Pneumatic Pickle Fork Set

- Use to separate ball joints, tie rods, & Pitman arms.
- Set contains two handles: knurled handle allows use of a hammer; smooth handle fits in a pneumatic hammer.
- Three sizes of pickle forks included: 1-1/8", 15/16", and 11/16".



Inner Tie Rod Wrenches (Standard & HD)

Universal wrench will fit on all styles and allow the technician to un-screw the tie rod link for replacement.

7484

Unique lever design will turn hex rack ends or hex shafts from 1" to 1-5/8" (25-41mm).

7500

Unique cam design cover sizes from 1-1/4" to 1-5/8" (33-41mm) hex, 2 flats, round or any style rack ends.

7501

Unique cam design cover sizes from 1-1/2" to 1-7/8" (38-48mm) hex, 2 flats, round or any style rack ends.

Scan Tools / Code Readers



3111PRO

OTC Trilingual Scan Tool OBD II, CAN, ABS & Airbag

Fix it Faster! Expanded Domestic and Asian ABS & Airbag coverage. Now with over 4.3 million verified fixes at the touch of a button! Compatible with all 1996 and newer cars and light trucks.

Airbag (SRS) & ABS coverage:

1996-2010 GM, Ford and Chrysler
1996-2009 Toyota, Honda, Hyundai and Nissan.

Enhanced code request For GM, Ford, Chrysler, Honda, Hyundai, Nissan and Toyota vehicles.

Displays additional live engine data: Now over 300+ possible PIDs. View engine RPMs, coolant temperature, Oxygen sensor readings and more!

AutoID™ Automatically retrieves VIN from vehicle and decodes to Year/Make/Model.

Component Locator Text descriptions indicate where the vehicle component is located.



3108N

OTC Pocketscan® Code Reader

- View LIVE engine data.
- Automatically reads DTC's.
- Erases DTCs.
- Reads and displays MIL status.
- Reads and displays I/M monitors.

3109N

OTC Trilingual OBD II/EOBD and CAN Scan Tool

- AutoID™ automatically identifies most 2000 and newer vehicles.
- Graph live data.
- Read and erase diagnostic trouble codes.
- Read and display LIVE sensor data.
- Read and display freeze frame data.



3418

OTC Heavy-Duty Code Reader

- Class 4 – 8 truck coverage.
- HD J1587 / J1708 and J1939 CAN, Engine, Transmission / ABS coverage and more for diagnostic trouble codes!
- Read and clear diagnostic trouble codes.
- Provides on screen DTC definitions or heavy-duty standard codes.
- Battery powered for off vehicle use.
- Internet update capable.

Applications:

Tow trucks, recreational vehicles, cement trucks, dump trucks, garbage trucks, buses, step vans, municipal vehicles, refrigerated trucks, and conventional trucks.

Heavy-Duty Standard compliant construction, marine, agriculture, & industrial diesel power plant configurations!

Includes: 9-Pin deutsch cable, 6-Pin deutsch cable, operations manual, 3-year warranty, and soft nylon carrying case.

Spectrum Work Lights

- AC/DC Rechargeable
- Li-Ion battery
- Magnetic base
- Bright LEDs - 50,000 hour life
- Adjustable 60° angle
- Slip resistant textured body
- Impact and water resistant
- Limited Lifetime Warranty

5550

Spectrum Solar 10W LED Work Light with UV Top Light



5551

Spectrum Trio 9W LED Work Light with 3W LED Top Light



5552

Spectrum 30+4 30 Pc. LED Work Light with 4 Pc. LED Top Light



5550 Specifications	5551 Specifications	5552 Specifications
10W LED Work light with UV Top Light	9W LED Work light with 3W LED Top Light	30 Piece LED Work light with 4 Piece LED Top Light
LI-ION Rechargeable Battery – 3.6V 2250 mA, AC/DC	LI-ION Rechargeable Battery – 3.6V 2250 mA, AC/DC	LI-ION Rechargeable Battery – 3.6V 2250 mA, AC/DC
Charger Input AC 100 ~ 240V; 50/60Hz; DC12V ~ 24V	Charger Input AC 100 ~ 240V; 50/60Hz; DC12V ~ 24V	Charger Input AC 100 ~ 240V; 50/60Hz; DC12V ~ 24V
Power Output: 5.0V 1000 mA	Power Output: 5.0V 1000 mA	Power Output: 5.0V 1000 mA
Charger Time: 3.5 ~ 4.0 hours	Charger Time: 3.5 ~ 4.0 hours	Charger Time: 3.5 ~ 4.0 hours
Active Time: 2.5 hours	Active Time: 3.0 hours	Active Time: 4.0 to 5.0 hours
Storage Temperature: -4°F to 158°F; -20°C to 70°C	Storage Temperature: -4°F to 158°F; -20°C to 70°C	Storage Temperature: -4°F to 158°F; -20°C to 70°C
Operating Temperature: 23°F to 122°F; -5° to 50°C	Operating Temperature: 23°F to 122°F; -5° to 50°C	Operating Temperature: 23°F to 122°F; -5° to 50°C
PS: LED Sector: 170°	PS: LED Sector: 25°	PS: LED Sector: 15°
At 50 cm: 350 LUX (750 LM)	At 50 cm: 4000 LUX	At 50 cm: 2250 LUX
Waterproof Grade IP65	Waterproof Grade IP65	Waterproof Grade IP65

NEW



8330

8330-RP

8330

Resurfacing Grinder – Medium

- Cleans dirt, rust, and corrosion from many surfaces including hubs, rotors, inside wheel edges, and other large surface areas.
- Can resurface up to 400 hubs before replacement of media is required.
- Recommended for up to 1500 RPM.

8330-RP

Two replacement discs for 8330.

NEW



7485

Locking Collar Rack Wrench

- Ideal for steering service, wheel alignment, strut cartridge, small dia. exhaust, and general pipe adjustment.
- Unique, two-piece design wraps around steering components.
- Permits service or adjustment of steering components without having to remove end.
- For use with diameters of 1" to 1-7/8" (25.4 mm to 47.625 mm).
- Eccentric shape of cam automatically adjusts to component diameter.
- 1/2" Sq.Dr. for maximum power with Ratchets, Extensions, and Breaker Bars.

Oil Service

5911

OTC Drain Plug Pro™

- Remove oil drain plug without dropping or touching the plug or hot oil.

5961HD

OTC Heavy-Duty Drain Plug Pro™

- For Agricultural, Commercial, and Heavy-Duty Vehicle Applications.

5961

OTC Drain Plug PRO Kit

- Standard drain plug attachment.
- Low profile drain plug attachment.
- 17mm hex attachment for internally driven drain plugs.
- 5/16" bit driver attachment.



5911

5961

5961HD

Wrenches

7400

Ratcheting Chain Wrench

This multi-purpose tool will grip parts of nearly any shape. It features a ratcheting head design that lets you turn in either direction without removing wrench from the work.

- 13" handle with capacity from 1/2" to 4-3/4" O.D.

7401

Ratcheting Chain Wrench

This multi-purpose tool will grip parts of nearly any shape. It features a ratcheting head design that lets you turn in either direction without removing wrench from the work.

- 19" handle with capacity from 3" to 6-3/4" O.D.

6969

Ratcheting Chain Wrench

- Ratcheting action makes it possible to re-grip without removing wrench.
- Handles parts of most any shape... round, square, hexagon, or octagon.
- Handle is 24" long; chain grips objects ranging from 3" to 6-1/2" O.D.

7206

Multipurpose Strap Wrench

You'll find many uses for this heavy-duty strap wrench. The 53" long nylon strap won't mar precision surfaces of shafts, pulleys, or other components. Useful on engine, transmission, and drive pulleys up to 16 inches. Special head design self-tightens the strap as force is applied to the lightweight, 12" long handle.

Fasteners

5900A

Master TORX® Socket Set

- 52-piece, professional socket set in a blow-molded case. Hundreds of applications from front to rear on cars and trucks:
- Seat belt bolts
 - Engine assemblies
 - Bumpers
 - Door strikers & latches
 - GM front-wheel drive front wheel bearings
 - Truck box liners
 - Interior and exterior trim screws
 - Tail lamp lenses & assemblies
 - Headlight bezels
 - Brake rotor bolts
- Styles available: TORX, TORX PLUS, tamper-resistant TORX and external TORX.
- Made from superior S2 steel to meet or exceed torque specifications.



5900A

TORX® Individual Socket Sets

6100 Standard TORX® Socket Set T10 – T60 (12 pc)

6150 External TORX® Socket Set (7 pc)

6135 Universal Brake Caliper Socket Set (9 pc)

5905 Tamper-Resistant TORX® PLUS Socket set (11 pc)

6145 Tamper-Resistant TORX® Socket set (7 pc)

5931

External Torx® PLUS Socket Set (8 pc)

5942

XZN Super Short Socket Bit Set (8 pc)

6160

Fraction Hex Socket Set (7 pc)

6170

Metric Hex Socket Set (7 pc)

6180

TORX® Plus Socket Set (9 pc)



6100

Fuel Injection Tools

7448A

Canister-type Fuel Injector Cleaner

Simply and completely clean a vehicle's fuel system with the 7448A Fuel Injector Cleaner.

With the addition of a quick-connect fitting, the removable hose can be thoroughly cleaned for storage and extending the life of the product. An included blowout fitting adapts to shop air supply to remove residual cleaner from hose lines.

The 7448A also includes our Fuel Injection Application Manual showing OE fuel pressure specs, fuel pump disconnect points, return line information and the adapter reference to OTC pressure adapter kits (6550PRO). Covers vehicles from 1997 through 2013.



Improved control valve

Ball valve when quick response is needed

Blow out fitting

Quick connect fitting for removable hose

Hose for gasoline and ethanol blends meets SAE standard 30R9

NEW



6550

Master Fuel Injection Kit

Test fuel injection systems on most GMs, including GM TBI, Ford, Chrysler, and Jeep vehicles. Also works on imports, including CIS and CISE fuel systems.

- 0-100 PSI fuel pressure gauge.
- 35 of the popular OTC fuel injection adapters, each equipped with a quick-connect Schrader valve.
- '97 - '13 Fuel Injection Service Application Manual.
- Replacement seal kit also included.



6550PRO

Pro Master Fuel Injection Service Kit

Covers 100% of vehicles sold in North America '97-'13.

Perform fuel pressure testing, diagnose weak fuel pumps or restricted filters, test for fuel flow and perform leak-down tests. Use to clean injectors and intake systems. Kit includes:

- 0 - 100 PSI Fuel Pressure Gauge.
- 47 of the popular OTC fuel injection adapters, each equipped with a quick-connect Schrader valve.
- '97 - '13 Fuel Injection Service Application Manual.
- Replacement seal kit also included.



6550UPD

Professional Fuel Injection Update Kit

Upgrades existing 6550 Master Fuel Injection Service Kit into the 6550PRO. Kit includes:

- 12 OTC fuel injection system adapters each with a quick connect Schrader Valve.
- 1997 - 2013 Fuel Injection Service Application Manual.



4480

Basic Fuel Injection Service Kit

- Performs running, residual, rail and flow rate pressure tests.
- Kit includes adapters, hoses and fittings to test fuel injection systems.
- Kit includes two popular adapters for import vehicles as well as the GM TBI adapter.
- Professional dual scale gauge reads 0-100 PSI and 0-700 kPa with relief valve, fuel discharge hose and rubber boot.
- Packaged in blow molded carrying case.

Suspension Tool



7068
Upper Control Arm Bushing Service Set
 Now you can easily replace press-in type upper control arm bushings on most rear wheel drive Chrysler, Ford, and GM vehicles. Mechanical screw power does the work. Set includes C-frame, screw assembly, and all adapters needed for quick removal or installation of bushings without removing or damaging the control arm.

Spring Compressors



7045B
Front Coil Spring Compressor
 This compressor fits most late-model rear wheel drive domestic vehicles in which the coil springs are between the upper and lower control arms. The tool features four case-hardened, self-aligning plates to ensure correct load distribution under tension. Includes two 3-3/8" ID plates and two 4" ID plates. Will not work on Mercedes-Benz vehicles.



7294
Front Coil Spring Compressor
 This compressor fits most late-model rear wheel drive domestic vehicles in which the coil springs are between the upper and lower control arms. The tool features four case-hardened, self-aligning plates to ensure correct load distribution under tension. Includes two 3-3/8" ID plates and two 4" ID plates. Will not work on Mercedes-Benz vehicles.

Strut Tools



6578
Hub Clamp Expander Kit

- For servicing struts, ball joints, or steering knuckles with pinch bolt mounts.
- Remove most stubborn struts and ball joints with ease.
- This separator mounts in the pinch bolt holes and drives the anvil into the pinch slot, expanding the mount for easy component removal.
- Use on aluminum or cast iron pinch mounts; includes 2 dowel sizes.



6494
Clamshell Strut Spring Compressor
 Servicing MacPherson struts is convenient and affordable with this compressor. It fits a wide range of struts and requires no special adapter shoes.

- Locking pins hold the compressor jaws in place.
- Tool compresses springs of 4 in. to 9 in. O.D., with diameters of 7/16" to 11/16".
- Built to use with an impact wrench.

Ball Joint Kits

Master Ball Joint Kits



6559
Ball Joint Master Service Kit
 The 6559 Ball Joint Master Service Kit offers complete coverage of Car and Truck/Van/SUV applications. With 70+ adapters, c-frame and application guide means there is nothing else to add for servicing ball joints.

- The majority of vehicles have press-in ball joints, so stop searching for make-shift solutions for servicing these vehicles – everything required is laid out in this one complete kit.
- With a kit of this magnitude, finding the correct adapters and using them correctly is key to minimizing service time. That is exactly what the included ball joint application guide is designed to do – contains application charts and diagrams with step-by-step instructions.



6529
Car Ball Joint Master Service Kit

- This 50+ adapter kit is the most complete Car ball joint service kit available, and the first of its kind on the market.
- With 70% of OEM's having cars with press-in ball joints, this kit is designed to service those applications.
- This kit is a subset of the 6559 and includes 50+ adapters, C-Frame, Ball Joint Application Guide, and Location Card all provided in 2 cases.



6539
Truck Ball Joint Master Service Kit

- This 55+ adapter kit is the most complete Truck/Van/SUV ball joint service kit available.
- With the majority of Truck/Van/SUV applications having press-in ball joints and universal joints, this kit is designed to service those applications. (note; covers same applications as the 8031 Chrysler/Jeep Truck/Van/Suv Ball Joint Kit without requiring larger C-Frame).
- This kit is a subset of the 6559 and includes 55+ adapters, C-Frame, Ball Joint Application Guide, and Location Card all provided in 2 cases.

Strut Service

StrutTamer Extreme

Simply the most effective compressor for virtually any straight, conical, or offset spring.

- Extreme duty design to handle the heavier springs found on mid- and some full-size truck strut assemblies.
- Frame includes cross bracing at arm mount locations - standard. This eliminates frame flex when compressing heavier springs.
- 2:1 reduction gearbox - standard. Allows for a 2:1 torque compression increase when compressing struts.
- Lock rings to hold arms in position - standard. This eliminates arms from spreading or sliding when compressing offset or unique strut configurations.
- Four-point locking jaws securely hold the spring in place.
- Open-ended design means you can take the strut in and out, quickly and easily.
- The arms adjust in and out, up and down, to accept many sizes of springs. (2-1/2" to 10" diameter) (2-1/2" to 24" vertical stroke)
- Extra long 3-bar handle gives user the leverage needed to compress heavier strut springs.
- No need to change shoes for different size springs.
- Easy to transport when mounted on optional stand (No. 6592 – StrutTamer Extreme with stand; No. 6582 – stand only)



6591
 StrutTamer Extreme strut spring compressor. Includes 6591-1 upper arm clamps and 6587 2:1 reduction gearbox.

6592
 StrutTamer Extreme strut spring compressor. Includes 6591-1 upper arm clamps, 6587 2:1 reduction gearbox and 6582 mobile stand.

Intermediate Ball Joint Kit



6530
Ball Joint Intermediate Service Kit

- This 20+ adapter kit covers many Truck/Van/SUV applications and some car applications.
- With the majority of Cars and Truck/Van/SUV applications having press-in ball joints and universal joints, this kit is designed to service many of those applications.
- This kit is a combination of 7249, 7918, and 7996 kits, and includes 20+ adapters, C-Frame, and Application Diagrams all provided in a case.

Starter Ball Joint Kit



7249
Ball Joint Starter Service Kit

- This starter kit is the backbone to ball joint, U-joint, anchor pins, and many other general pressing operations. Kit includes 5 adapters and C-Frame provided in a case.



6539-1
Import Truck Ball Joint Adapter Set

- 35 adapters included to remove & install ball joints.
- Works on upper and lower ball joints on Toyota, Honda, Acura, Hyundai, KIA, Infinity, Isuzu, and Nissan Trucks, Vans, and SUV's with press in ball joints.
- Vehicle application chart and diagrams included. Does not include the 7248 C-Frame press.



6539-2
Chrysler/Mitsubishi Truck Ball Joint Adapter Set

- 35 adapters included to remove & install ball joints.
- Works on upper and lower ball joints on Chrysler, Dodge, Jeep, Plymouth, and Mitsubishi Trucks, Vans, and SUV's with press in ball joints.
- Vehicle application chart and diagrams included. Does not include the 7248 C-Frame press.



6539-3
Ford/Mazda Truck Ball Joint Adapter Set

- 32 adapters included to remove & install ball joints.
- Works on upper and lower ball joints on Ford, Lincoln, Mercury, and Mazda Trucks, Vans, and SUV's with press in ball joints.
- Vehicle application chart and diagrams included. Does not include the 7248 C-Frame press.



6539-4
GM Truck Ball Joint Adapter Set

- 28 adapters included to remove & install ball joints.
- Works on upper and lower ball joints on Buick, Cadillac, Oldsmobile, Pontiac, Chevrolet, GMC, and Hummer Trucks, Vans, and SUV's with press in ball joints.
- Vehicle application chart and diagrams included. Does not include the 7248 C-Frame press.

TCE 4230 Bosch Swing Arm Tire Changer

Swing arm tire changer designed for servicing standard and high performance tires.

- Services a large variety of tire sizes up to 44" in diameter.
- Includes helper system with 2 points of contact for challenging tire work.
- External clamping capacity up to 26" without the need for adapters.
- Features adjustable jaws with built in inflation.



The pneumatic following arm assists in mounting and demounting low profile tires.



Replaceable plastic inserts protect the rim surface from metal contact to prevent accidental damage.
(P/N 1695101608810 / 5pk)



Telescoping adjustments on the bead breaker shaft increase wheel width and tire diameter capacities.



TCE 4230SFA Bosch Swing Arm Tire Changer with Helper Assembly

- Swing arm tire changer designed for servicing standard and high performance tires.
- Services a large variety of tire sizes up to 44" in diameter.
- Includes helper system with 2 points of contact for challenging tire work.
- External clamping capacity up to 26" without the need for adapters.
- Features adjustable jaws with built in inflation.



The pneumatic following arm assists in mounting and demounting low profile tires.



Replaceable plastic inserts protect the rim surface from metal contact to prevent accidental damage.
(P/N 1695101608810 / 5pk)



Telescoping adjustments on the bead breaker shaft increase wheel width and tire diameter capacities.



TCE 4435THP Bosch High Performance Tire Changer

- Tabletop system with 24" internal and 22" external clamping.
- Ability to accommodate up to a 43" diameter assembly.
- 25% faster inflation system than benchmarked competition.
- 2 stage variable speed operation for fast operation and quick turnaround.
- Robust 5 1/2" x 5 1/2" automatic tilt tower with pneumatic lock.
- 40% increase in bead breaker power versus the previous model.
- 30% less mount/demount flexion versus benchmarked competitive offerings.
- 3 point helper system automatically maintains proper bead position for effortless orientation.
- Extreme structural rigidity for reduced flexion even for the most difficult UHP or RFT.
- 3 position adjustable bead breaker.
- Equipped with the TCE 320 Assist Assembly and bead breaker board to reduce operator effort on the toughest tire & wheel combinations.



Zeppa Bead Pressing Device (standard)
(P/N 1695103261810)

OCL 8850 Bosch On Car Brake Lathe Faster. Better. Stronger.

Efficiently corrects lateral runout, DTV (disc thickness variation) and produces a superior finish versus competitive models.

- Standard adapters for 95% vehicle coverage in standard package.
- Delivers the industry's most accurate and precise results for finishing rotors.
- Bidirectional drive unit, eliminating the need to "flip" the lathe.
- Design saves time, eliminates need for full disassembly of brake system.
- Compact design fits in tight wheel wells.
- Mounts to the same machined surface as caliper.



Shop Equipment



- ### 5300 OTC Stinger 3-Ton Jack Pack
- This jack pack includes a 3-ton service jack (5303) with lifting range of 5-3/4" to 18-1/2" and a pair of 3-ton jack stands (5372) with a base of 8-1/4" x 7-1/2" and height range of 12" to 17-11/16".

2-1/4 - / 3-Ton Hydraulic Service Jacks

- Flanged upper body edge increases strength to resist twisting.
- Built-in safety overload system/ prevents use beyond their rated capacity.
- Rear swivel casters, for easy maneuvering and positioning.
- These jacks have 4" saddle dia., 21" overall reach, 6-1/2" frame height, 39-1/2" handle length, and a floor space of 13-1/2" x 24-1/2".

5302
2-1/4-ton capacity with a lifting range of 5" to 18".



5303
3-ton capacity with a lifting range of 5-3/4" to 18-1/2".

1774B 10-Ton Capacity Ratcheting Jack Stands (pair)

- These ratcheting jack stands are highest quality steel and factory tested to ANSI PALD standards.
- The form-fit saddle design and 12" x 14" base ensures stability.
- Height range is 20" to 31-1/2".



1784D OTC Stinger 3-Ton, 6-Ton and 12-Ton Jack Stands

- Formed and welded steel base for strength; self-locking ratchet handle cannot be released under load. Durable baked enamel finish resists corrosion.
- Stands conform to ANSI PALD load rating standard; factory tested before shipment.

- 5372**
- Pair of 3-ton jack stands.
 - Base: 8-1/4" x 7-1/2".
 - Height range: 12" to 17-11/16".

- 5373**
- Pair of 6-ton jack stands.
 - Base: 11-9/16" x 10-3/8".
 - Height range: 15-5/8" to 23-11/16".

- 1784D**
- Pair of 12-ton jack stands.
 - Base: 12-1/8" x 10-7/8".
 - Height range: 17-1/2" to 27-1/2".

4046 RamRunner two-stage hydraulic pump

RamRunner two-stage hydraulic pump with 3-position/4-way manual valve for double-acting rams, and a 6 ft. remote control cord. Supplied with one gallon and two quarts of oil.



5280 OTC Portable Diesel Particulate Filter Cleaner

- Robust design for long shop life.
- High pressure cleaning process for thorough cleaning of ash from DPF – produces 10 times the burst energy of competitive low pressure units.
- Burst Quick Check identifies if filter is too plugged for proper cleaning.
- Movable with locking wheels for placement throughout the shop.
- Computer controlled process based on OE requirements for start-to-finish cleaning without constant technician monitoring.
- Containment of hazardous ash for easy disposal.
- HEPA Filter Air Exhaust System included to exceed shop environmental air standards.
- Operates on standard 115V outlet.
- Proven to clean to over 92% efficiency.
- Third-party OEM test results using pin gauge measurement with approved OTC adapters and burst cycles. Actual results may vary.

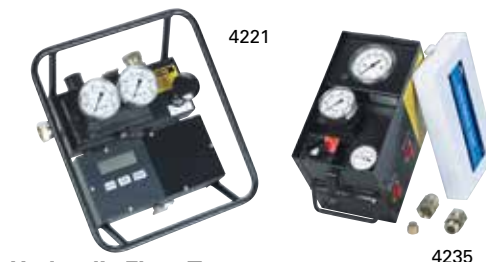

4221 Hydraulic Flow Testers

50 and 75 GPM hydraulic oil flow testers accurately measure oil flow, temperature, and pressures against manufacturers' specifications. Troubleshoot hydraulic circuits and isolate faulty components on mobile equipment, machine tools, fork lifts, agricultural and industrial tractors, and equipment (open or closed) hydraulic systems with capabilities up to 75 GPM at pressures to 5,000 PSI. Models include features such as an automatic pressure compensating load valve that lets you increase flow without affecting the pressure settings. Temperature flow and RPM readings are displayed in metric or English, and accurate to within plus or minus 2% of full scale. Each tester is protected by a safety disc, which ruptures automatically if pressures exceed the upper limits.

4221
75 GPM hydraulic circuit tester. Comes with two pressure gauges and three 9-volt batteries.

4235
50 GPM hydraulic circuit tester with single liquid-filled pressure gauge. Includes two adapter unions for 3/4" NPTF fittings.

Bottle Jacks



5221 20-Ton

5213 12-Ton

5213T 20-Ton

- Base, pressure cylinder, and oil reservoir form one internal part, which results in a stronger jack.
- Piston never contacts cylinder, so pressure will be absorbed and not damage jack if vehicle tilts.
- The No. 5213T is telescopic, allowing for very low initial height with high lifting.

3095 Heavy-Duty Digital DEF Tester

Ensure the proper operation of Class 7-8 trucks utilizing the SCR system with accurate Diesel Exhaust Fluid solution displayed on screen.

- Digital Display
- Displays UREA percentage
- Displays washer fluid freeze point

The OTC 3095 makes testing a simple and quick process for an operator or technician.



5281 OTC DPF Thermal Processing Unit

- Designed to facilitate the cleaning of filters – with high amounts of wet soot, and unburned hydrocarbons.
- Pre-programmed thermal profile controls temperature "ramp up" and "cool down" to reduce the risk of cracking the DPF.
- Includes "pre-treat" cycle for oil-soaked filters.
- Holds temperature constant for two hours to ensure complete regeneration of filter.
- Built-in electronic safety lock prevents unauthorized opening of the door when temperatures exceed 200 degrees F.
- Large chamber accommodates various DPF sizes and shapes. Front access door allows for easy access to the thermal chamber.



4026 Air/Hydraulic Power Unit

- Heavy-duty aluminum body for durability and light weight.
- 10,000 PSI air/hydraulic pump.
- A perfect replacement pump for body and frame straightening equipment.
- Performs in either vertical or horizontal positions.
- Rotary-style pressure release provides superior operator control.



Heavy Duty Equipment

5105B

1,100 lb. Capacity High-Lift Dual Wheel Dolly

- Effortless air-powered hydraulic lift system for a variety of applications.
- 0 to 42" lifting range.
- Six-inch lateral adjustment.
- Tilt adjustment of +15° to -8° ensures easy alignment.
- Features four swivel casters, two locking, for enhanced mobility.



1591B

10-Ton Combination Air Lift & Support Stand

- 40" removable handle and 8' air hose.
- Covered by OTC Lifetime Warranty®.

Specifications:

Capacity – 10 tons (at 200 PSI air).
Stroke – 10-7/8".

Minimum height (unpinned, no extension) – 18-1/4".

Maximum height (pinned in top hole, with extension) – 51-1/4".



5292

27.5-Ton Capacity Under-Axle Jack

- Features class-leading 27.5 ton capacity.
- Robust design with completely sealed piston.
- New lever design and pneumatic release valve for more precise release control.
- Power return allows lowering with no load.
- Includes two height adapters for flexibility.
- PALD compliant.
- Minimum retracted height (with saddle only): 8-1/4".
- Maximum extended height (with screw extended and large adapter): 21-3/8".
- Stroke: 4.9375".
- PSI range: 90 to 175.



1590

10-Ton Air Lift

- Adjustable lifting saddles and an extra-wide stance for extra stability.
- Automatic mechanical safety catch engages in five height positions.
- Two large swivel casters and pneumatic tires make it easy to maneuver, even on loose gravel.
- Covered by OTC Lifetime Warranty®.



Specifications:

Capacity – 10 tons (at 200 psi air)

Air pressure – 100-200 psi

Lifting range – 13"-52"

Saddle spread – 29" – 41-3/4"

Saddle – 4" X 5-1/4"

Height – 67-1/2"

Width – 41"

Length – 36"

Distance from lift arm to floor support – 12-1/2"

572913

Optional wide saddle set for 1590, saddle 4" x 5 5/8".

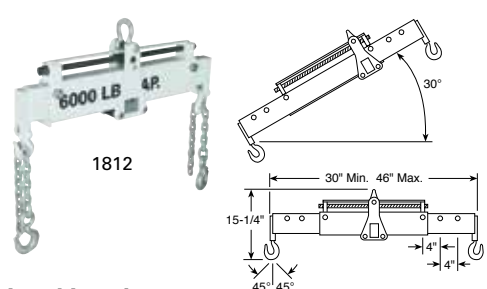

Load Leveler

- Improved design over conventional spreader bars.
- Carriage on main support beam moved by turning lead screw; this permits fine adjustment of the tilt angle of component being lifted.
- Turn lead screw manually or with air-powered tools.
- Spreader bar adjustment secured with locking bolts.
- Chain grade is 80.
- Covered by OTC Lifetime Warranty®.

1812

Load Leveler. Max. lifting capacity: 6,000 lbs.; distance between hooks: min. 30", max. 46".

1822

Load Leveler. Max. lifting capacity: 10,000 lbs.; distance between hooks: min. 36", max. 56".

OTC Transfer Tanker

- Draining oil from a large displacement engine and getting it to your bulk storage container is a snap.
- Used oil is collected in the 15-gallon reservoir, and then rolls smoothly on 4" free-wheeling casters to your storage location.
- Pump moves five gallons a minute through the 8-foot transfer hose.
- Low profile, measures 7-1/2" from floor to top of reservoir.
- Can also be used for transferring antifreeze.

5077 – Transfer Tanker equipped with an electric pump (No. 528093).

5097 – Transfer Tanker equipped with a pneumatic pump (No. 529966).



1572

Car Dolly (3,600 lbs., capacity pair)

- Innovative patent-pending design – clamps directly to pinch welds to prevent slippage during use.
- Independent units eliminate the need to adjust dolly width for different vehicle designs.
- Each unit has an independently adjustable threaded lift saddle with rubber pads to protect the vehicle frame.
- Universal design for use on all vehicle types without additional adapters.
- Provides easy movement of FWD vehicle after removal of drive train.
- 5" Polypropylene casters.
- Each unit has 1,800 lbs. capacity (3,600 lbs., pair) with low height of 9" and high of 14".
- May be used with or without tires on vehicle.



2- & 3-Ton Service Jack

- Ergonomic handle for user comfort & easy mobility.
- Foot pedal for quick approach of the lifting saddle to load. Built-in tray for fasteners and tools.
- CE certified, PALD compliant.
- Covered by OTC Lifetime Warranty®.

5202 – 2-ton service jack.

Min. height 3"; Max. height 18-1/4".

5203 – 3-ton service jack.

Min. height 5-1/2"; Max. height 20-1/2".



6- & 10-Ton Heavy-Duty Service Jack

- Ergonomic handle for user comfort & easy mobility.
- Foot pedal for quick approach of the lifting saddle to load. Built-in tray for fasteners and tools.
- CE certified, PALD compliant.
- Covered by OTC Lifetime Warranty®.

5206 – 6-ton HD service jack.

Min. height 6-11/16"; Max. height 22-13/16".

5210 – 10-ton HD service jack.

Min. height 6-11/16"; Max. height 23-13/16".



1533

OTC Aluminum Racing Jack Pack

- **1532** – Jack lifts two tons and weighs only 43 lbs.
- Five pumps to max. height – 18".
- Low profile 3-1/2" makes it perfect for ground hugging, high performance cars.

1582 – 2-ton aluminum jack stands.

- 10-1/4" min. height, 15-1/4" max. height.
- Made from aircraft-grade aluminum.

25-Ton & 55-Ton Capacity Shop Presses

- Raise and lower bed easily on this tough, economical press that is ideal for pressing rear axle bearings, piston pins.
- Hand-operated winch and cable mechanism adjusts lower press bolster.

1833

25-ton capacity press includes OTC No. 4002 handpump and 6-1/4" stroke ram.

1850

55-ton capacity press includes OTC No. 4016 hand pump and 6-1/4" stroke ram.



6,000 lb. Capacity Heavy-Duty Mobile Floor Cranes

- Three boom positions for capacities of 4,000, 5,000, and 6,000 lbs for large engines and engines/transmissions combined.
- Usable reach of nearly 92".
- Boom swivels for vertical and lateral positioning.
- Legs extend to straddle extremely large tires.

1814 – 6,000 lb capacity crane with electric/hydraulic pump and remote control.

1813 – 6,000 lb capacity crane with two-speed hydraulic hand pump.



Kingpin & Brake Anchor Pin Pusher

- Replace torch-and-hammer methods for getting the job done quickly and easily. Five special collars and two pins allow this unit to work on both straight and tapered kingpins and accommodates sizes from 7/8" to 2" in diameter and up to 11-1/4" long. The tool delivers 30 tons of hydraulic force to push out even the most corroded kingpins. A job that could consume the better part of a day is done in minutes. The anchor pin can be removed quickly by using the special adapter installed in the pusher's base block and the unit positioned over the brake's spider.
- Works on many models of trucks and buses.
 - 27-1/2" high x 8-1/2" wide.
 - 30-ton capacity.
 - Includes No. 4002 hydraulic hand pump, No. 9767 hose, No. 9798 hose-half coupler, No. 4121 Power Twin 30-ton ram, and No. 29424 anchor pin adapter.

4240 – Complete kingpin and anchor pin pusher set with hydraulics.

4241 – King- and anchor-pin pusher with anchor pin adapter without hydraulics.



4295

Wheel Stud Service Kit

- Installation done by pushing on the head, eliminating the need for threaded adapters.
 - Reduces number of adapters required
 - Reduces damage to studs, hubs and bearings
 - Increases ease of use
- Remove and install 10 studs in only 10-15 minutes
- Can be powered with an impact wrench, no hydraulic power source required.
- No need to remove hub from vehicle.

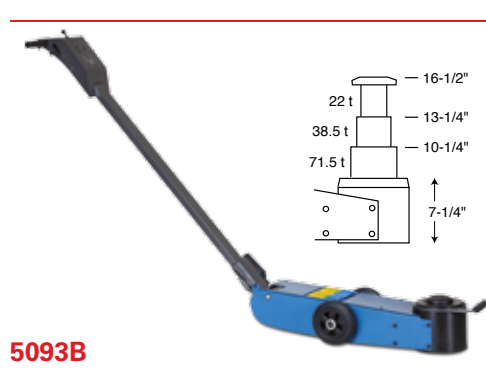

5093B

3-Stage Under-Axle Jack

- Three-stage lift capacity 20T, 35T, and 65-ton. Ideal for lifting loaded trailers, buses, and other Class 7 & 8 vehicles.
- Features a high load-approach speed.
- Air-driven cylinder with pressure control knob for maximum user safety.
- 4-position handle: horizontal, 45 degrees, vertical, or collapsed.
- 7-inch minimum height for low clearance vehicles.
- Comes with a 3-15/16 in. (100 mm) lifting extension.
- Complies with ASME / PALD test requirements.

5130

OTC 1,000 lb. Capacity DriveMaster™ Driveline Lift

- Low profile of 7".
- Lift range: 23" to 30".
- Pivoting pump handle +/- 15° tilt in each direction.
- Includes 553516 differential mounting adapter. Mounts easily using existing bolt patterns. Fits the most common differentials currently in use on Category 7 and 8 Heavy Duty Trucks. Including: Eaton, Fuller, Rockwell, Meritor, Spicer, International, and Mack.
- CE certified, PALD compliant.

Optional adapter kits

558382 – Auxiliary box adapter.

561949 – Light duty transmission adapter.



OTC Power Train Lift

- These lifts will handle engine and transmission assemblies, gas tanks, drive axle assemblies, engine/transaxle assemblies, electric bus batteries, and more.
- Scissors-type design allows access to all four sides of a component.
- Lifting and lowering motion controlled by hand-held remote.
- Table tilts ±15° side-to-side, or fore and aft.
- 20" x 32" tilt table.
- Larger casters accommodate heavy loads.

5285 – 1,650 lb. Capacity Lift. Air / hydraulic operation – Foot control pump (2510A) with hose allows movement around lift. Minimum height is 29" with a 72" maximum height.



1585A

Power Train Lift 1,250 lb. Capacity

- For easy removal and installation of engine/transaxle assemblies on FWD vehicles. Also handy for pulling rear ends, leaf springs, and more.
- Includes 4020 air/hydraulic pump.
- Your shop air supply is the only thing you need to get the precise control offered by this OTC power train lift.
- Width between wooden support blocks is adjustable from 0-29". Load is secured with a tough nylon strap.

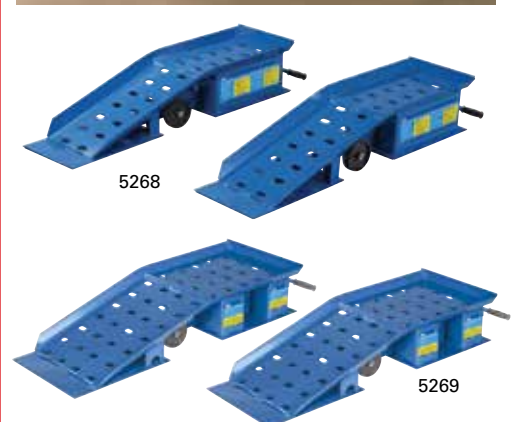

20-Ton Truck Ramps

- Long, retractable T-handle enhances mobility.
- Non-skid rubber matting prevents slippage during use.
- Durable, heavy-duty rubber wheels.
- Capacity per pair is 20 tons
- Covered by OTC Lifetime Warranty®.

5268

20-ton truck ramps handle up to 10" tread width.

5269

Wide 20-ton truck ramps handle up to 16" tread width.

SERVICE CENTERS

Take advantage of one of our extensive Robinair Service Centers. Visit <http://www.robinair.com/automotive/service-centers> to find a location near you.

New for 2015: Unmatched 98.5% recovery

Robinair introduces its next innovation, the 34788NI and 34788NI-H, featuring an industry-leading 98.5% recovery efficiency for standard and hybrid vehicles and fully automatic function.



Features	34788NI	34788NI-H
Fully-Automatic Function: Program to recover, vacuum, leak test and charge without operating panel valves.	X	X
Automatic Oil Drain: A display reminds you to empty the graduated container to show the amount of oil to replace.	X	X
Oil Inject: Automatically inject oil back into the vehicle's A/C systems.	X	
Refrigerant & Oil Database: A/C system capacities for North American market vehicles (Optional - not included with the machine)	Optional	Optional
A/C System Flush: Flushes a vehicle's A/C system with refrigerant, eliminating any residual oil or other liquid. (Flushing adapters not included)		X
Save & print before and after service data: Allows the user to store before and after service information by vehicle and print this information to provide to a customer.	X	X
Visual & Audible Alarm: Notifies the user when service is complete, or if a problem has occurred.	X	X
Vacuum Leak Test: Monitors level after evacuation, informs of possible leak.	X	X
Automatic Air Purge: Eliminates system-damaging air without monitoring gauges or opening valves.	X	X
Automatic Refrigerant Refill: Maintains a user-selectable amount of refrigerant in an internal vessel and signals when it's time to change supply tank, no monitoring required.	X	X
Vacuum Feature: Defaults to 15 mins, programmable up to 99 mins. "Remaining time" is displayed.	X	X
Display: Multilingual.	X	X
Refrigerant Charging: Select a charge mode from high or low side, or use both sides.	X	X
Refrigerant Management System: Displays refrigerant use and monitors remaining filter life. Prompts appear when 1/3 of filter life remains.	X	X
Electric Vehicle: Capable of servicing high voltage electric compressor A/C systems.		X
Printer.	Optional	Optional
Refrigerant Identifier.	Optional	Optional

34288 A/C Recover, Recycle, Recharge Machine

- The 34288 combines simple operation with superior accuracy. It recovers, recycles, evacuates, and recharges R-134A quickly and accurately.
- Meets SAE J-2788 standards recovering 95% refrigerant and charging to +/- 1/2 oz.
- Automatic Oil Drain: A display reminds you to empty the graduated container to show the amount of oil to replace.
- Automatic Air Purge: Eliminates damaging air without monitoring gauges or opening valves.
- Displays refrigerant use and monitors remaining filter life. Prompts appear when 1/3 of filter life remains.



Multi-Purpose and Coolant Fluorescent Dye

MULTI-PURPOSE (engine oil, transmission) 16244, 16245

COOLANT 16885, 16890



16009

DiscovR Refrigerant Identifier

- Fast and Accurate. "Pass" and "Fail" lights clearly show if refrigerant is pure enough to be recovered.

Product Specifications:

Refrigerant: R134a
Input Power: 12 VDC
Accuracy: Pass/Fail - 95% pure R134a
Air Detection: Yes
Approvals: SAE J1771, UL/C



TIFZX

Heated Pentode® Refrigerant Detector

- Heated Pentode® sensor technology
- Tri-color visual leak size indicator
- Detects all CFC, HFC, HCFC's including R-12, R-22, R-123, R-134a, R-404a, R-407a, R-408a, and R-410a.



22791

InfraRed Refrigerant Leak Detector

- Advanced infrared sensor designed to last a minimum of 10 years.
- Three sensitivity levels down to 0.15 oz./year.
- Automatically recalibrates in highly contaminated areas to help pinpoint the exact location of the leak
- Won't trigger on oil or moisture.



34988

A/C Recover, Recycle, Recharge Machine

- The 34988 recovers, recycles, evacuates, leak tests, and recharges R-134a quickly and accurately. Automatic operation means less attention is needed!
- Fully-Automatic Function: Program to recover, vacuum, leak test and charge without operating panel valves.
- Automatic Dye Inject: Gives the user the ability to use the machine to inject UV dye into a vehicle's A/C system.
- Automatic Oil measure & Inject: The machine automatically determines how much lubrication oil needs to be injected back into the A/C system based on how much oil was taken out during recovery.
- Optional Refrigerant & Oil Database: Includes A/C Charge and Oil Capacities for North American market vehicles.
- A/C system flush: Flushes a vehicle's A/C system with refrigerant eliminating an residual oil or other liquid.



Robinair Manifolds

2-Way Brass Manifold



44150
Dual R12/134a Kit

45111
R134a Manifold Hose Kit

2-Way Aluminum Manifold



48510 R134A
• 90° Manual couplers
• 72" R134a Hose Set (1/2" ACME x 14mm)

47150 R12/134A
• 90° Manual couplers
• 72" R134a Hose Set (1/2" ACME x 14mm)
• 72" R12 Hose Set (1/2" ACME x 1/4" MFL)

Economy Manifolds



48134A
R134a manifold, hose set and service couplers

49134A
R134a aluminum manifold, hose set and service couplers

92500

Transmission Fluid Exchanger

You can have the vehicle in and out of the service bay in less than 20 minutes.

Our unique approach to exchanging fluid... through the transmission oil dipstick.

- No rusty fittings to break loose.
- Easy, convenient, and no damage to other engine components.
- Exchange oil in the pan before it passes through the transmission filter.
- Fittings prevent reverse hookup.

Operate through dipstick only, cooler line or a combination of the two!

- Exchange accuracy approx. +/- 1/4 qt.
- 32-qt. supply tank; 34-qt. waste tank.
- Unprecedented one-tenth quart flow metering for adding or subtracting fluid from the pan.
- Works with all types of automatic transmission fluid.
- Complete set of adapters for most foreign and domestic vehicles.



TIF7610

IR Thermometer PRO

- SoC (System-on-a-Chip) Technology - Complete IR design incorporated on a single chip, creating compact and lightweight design.
- Innovative optical lens - high accuracy measurements over wide temperature ranges. 10:1 distance to spot (D:S) ratios available.
- Laser pointer - Simply point at desired target and press the trigger for temperature reading.
- High/low pass filters with audible alarms for out of range measurements.
- Temperature modes - Maximum (MAX).



Refrigerant Tanks

17121

30 lb. tank, 1/4" fittings (25150, 25175, 25200B, 34234, 34300-2K, 34800 series).

17506

50 lb. tank, 1/4" fittings (17800A, 17800-2K, 17700A, 25150, 25175, 25200B series).



75240

Coolant and Battery Refractometer

Coolant scale range: 32° F/0° C to -60° F/-51° C.



Econo-Clean Coolant Service Accessories

75234

75134

75134

Coolant test strips.

75234

3-way heavy-duty truck coolant test strips.



UV Leak Detection Kits

- The easiest and most accurate gun available today.
- No guesswork - a pre-measured application every time.
- One squeeze injects a pre-measure amount (1/8 oz.) of dye. No more adding too much dye.



A/C Fluorescent Dye



16240

64 applications
One 8 oz. bottle

16241

64 applications
One 8 oz. bottle

16242

12 applications
Twelve 1/4 oz. bottles

16242

24 applications
Six 1 oz. bottles

TIF9010A

Slimline Programmable Scale

- Completely portable refrigerant scale, battery powered, can be used with all refrigerants.
- Extreme accuracy.
- 110 lb./50 kg capacity.



Robinair Vacuum Pumps

VacuMaster® Single Stage Vacuum Pumps

- 15115** - 1.5 CFM Vacuum Pump.
- 15310** - 3 CFM Vacuum Pump.
- 15115** - 5 CFM Vacuum Pump.



VacuMaster® 2-Stage Vacuum Pumps

- 15150** - 1.5 CFM Vacuum Pump.
- 15300** - 3 CFM Vacuum Pump.
- 15500** - 5 CFM Vacuum Pump.



CoolTech® Vacuum Pumps

- 15434** - 4 CFM Vacuum Pump.
- 15600** - 6 CFM Vacuum Pump.

