



High-Lift Wheel Dolly

- Effortless air-powered hydraulic lift system allows unit to be used as a multi-purpose lift in a variety of applications.
- 1,500 lbs. capacity provides 50% more lifting capacity than competitive high-lift wheel dollies.
- 42" lifting range.
- Six-inch lateral adjustment provides precise positioning of wheel assemblies.
- Tilt adjustment of +15° to -8° ensures easy alignment.
- Features four swivel casters, two locking, for enhanced mobility.
- Covered by the OTC Lifetime Marathon Warranty®.

No. 5105A – High-lift wheel dolly.
Wt., 360 lbs.



No. 5105

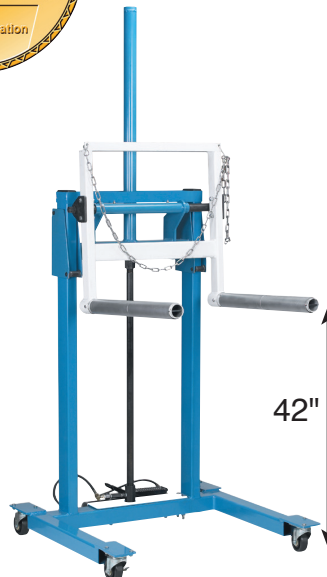

Forty-two inch lifting range means you can pull wheels even when they are off the ground.



Wheel Tipper



- Designed for both aluminum and steel wheels.
- Reduces back strain when tilting deflated wheel assemblies for maintenance—won't damage wheel rim.
- OTC Lifetime Marathon Warranty®

This heavy-duty wheel tipper makes handling those hard-to-manage truck tires easy, in or out of the shop.

To use the wheel tipper, simply deflate the tire and break the bead, then hook the wheel tipper to the rim of the wheel. With both hands on the wheel tipper, pull it towards you.

The wheel tipper makes an otherwise tough task effortless.

No. 5082 – Wheel tipper.

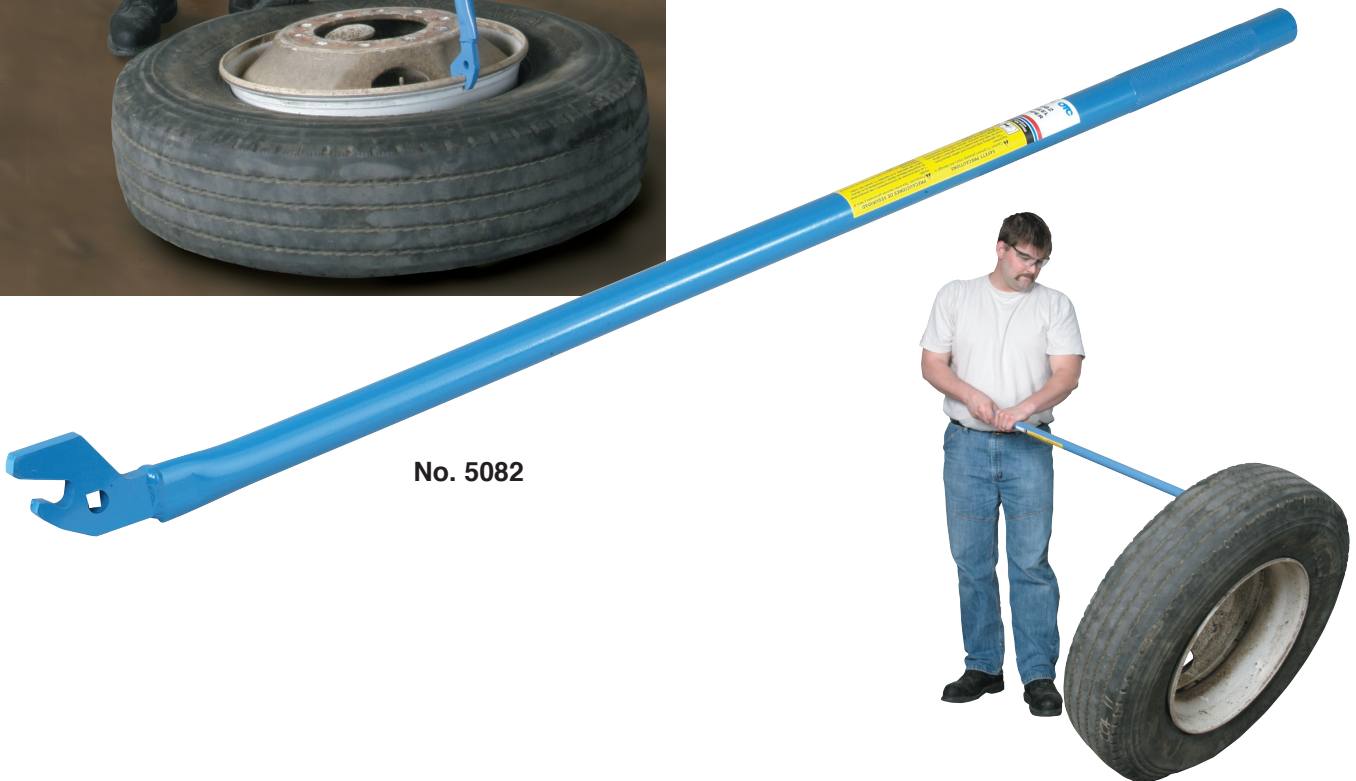

No. 5082