



1,500 lb. Capacity Easy Roller™

1580 Stinger Easy Roller™

- Provides simple and efficient method of moving a disabled vehicle around a shop environment.
- Fits tread widths up to 12"
- 4 heavy-duty phenolic casters
- 1,500 lbs. capacity per unit.
- Hydraulic lift mechanism with locking pin.

No. 1580 – 1,500 lb. Stinger Easy Roller™ (sold individually). Wt., 44 lbs.

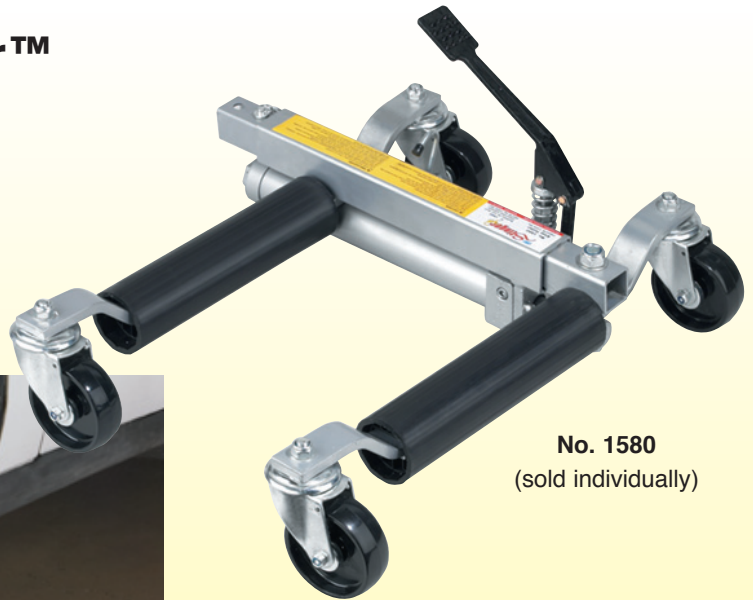

No. 1580
(sold individually)



No. 1581
(sold separately)

1581 Stinger Easy Roller™ Stand

This stand provides users of the 1580 with convenient storage rack for up to 4 Stinger 1580 Easy Roller Car Dollies (sold separately).

- Capacity: 4 Easy Rollers @ 44 lbs. each approx. 200 lbs. (1580's sold separately)
- Easy Loading / Unloading of units.
- Casters for easy mobility in shops and non-metal wheels to protect shop floor.
- Small profile for minimal space usage.
- Easy to assemble.
- Stinger 2-year warranty for materials and workmanship.

No. 1581 – Stinger Easy Roller™ Stand. Wt., 17 lbs., 3 oz.

1584 Four Stinger Easy Roller™ with Stand

- Includes 4 Stinger 1580 Easy Roller Car Dollies.
- Convenient storage rack for up to 4 Stinger 1580 Easy Roller Car Dollies.

No. 1584 – 4 Stinger Easy Roller™ Car Dollies with Stand. Wt., 193 lbs., 3 oz.



No. 1584