



655 Eisenhower Drive  
 Owatonna, MN 55060 USA  
 Phone: (507) 455-7000  
 Tech. Serv.: (800) 533-6127  
 Fax: (800) 955-8329  
 Order Entry: (800) 533-6127  
 Fax: (800) 283-8665  
 International Sales: (507) 455-7223  
 Fax: (507) 455-7063

Form No. 102424

**Parts List &  
 Operating Instructions**  
 for:

1812

**Load-Rotor®**

Max. Capacity: 6,000 lbs. / 2,720 kg

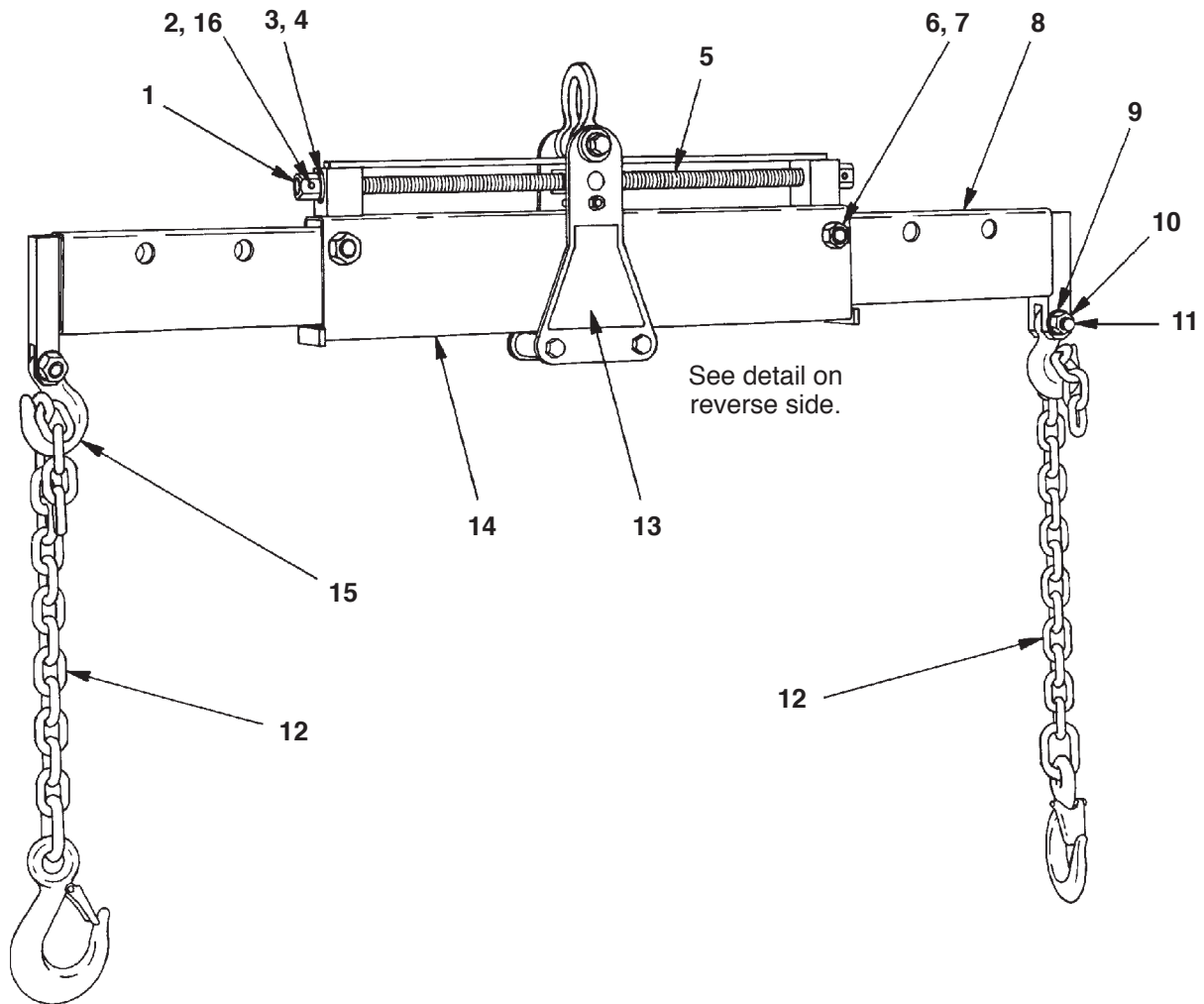

Item No.	Part No.	No. Req'd	Description
1	206675	2	Nut
2	10585	2	Roll Pin
3	206746	2	Thrust Bearing
4	16209	4	Thrust Washer
5	302241	1	Screw
6	16726	2	Hex Hd. Cap Screw (3/4-10 x 3-1/4" Lg.)
7	10216	2	Hex Nut (3/4-10)
8	44242	2	Inner Tube
9	13324	4	Washer (for 5/8" bolt)
10	10213	2	Hex Nut (5/8-18)

Item No.	Part No.	No. Req'd	Description
11	22045	2	Hex Hd. Cap Screw (5/8-18 x 2-1/2" Lg.)
12	302941	2	Chain & Safety Hook
13	302284	1	Warning Decal
14	51726-WH2	1	Main Tube
15	16051	2	Eye Grab Hook
16	10481	2	Roll Pin
			<b>Parts Included but Not Shown</b>
	304524	2	Capacity Decal

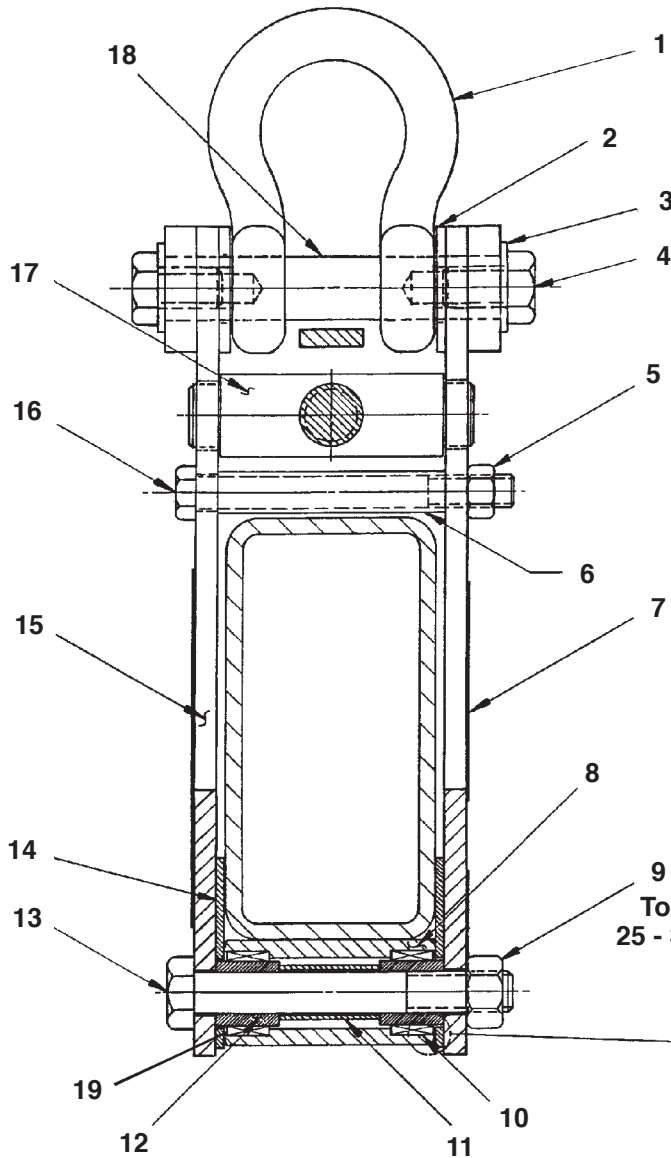

Refer to any operating instructions included with the product for detailed information about operation, testing, disassembly, reassembly, and preventive maintenance.

Items found in this parts list have been carefully tested and selected by OTC. **Therefore: Use only OTC replacement parts!**

Additional questions can be directed to the OTC Technical Services Department.

9  
Torque to  
25 - 30 ft. lbs.

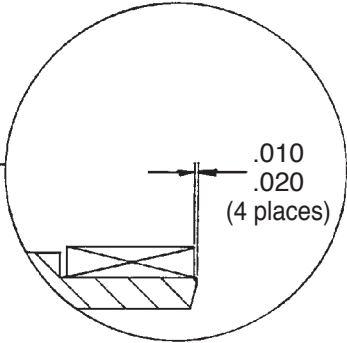

Note: Grease bearings (Item 10) before assembly.

Item No.	Part No.	No. Req'd	Description
1	206679	1	Anchor Shackle
2	12330	2	Washer (for 3/4" bolt)
3	12004	2	Washer (for 1/2" bolt)
4	10075	2	Hex Hd. Cap Screw (1/2-13 x 3/4" Lg.)
5	10204	1	Hex Nut (3/8-16)
6	206678	1	Spacer
7	11281	1	Trade Name Decal
8	302240	2	Roller
9	15013	2	Locknut (1/2-13; torque to 25-30 ft. lbs.)
10	209692	4	Needle Bearing
11	206680	2	Spacer
12	206681	4	Inner Bearing Race

Item No.	Part No.	No. Req'd	Description
13	13894	2	Hex Hd. Cap Screw (1/2-13 x 3-3/4" Lg.)
14	302225	2	Wear Pad
15	44240	2	Side Plate
16	14493	1	Hex Hd. Cap Screw (3/8-16 x 3-3/4" Lg.)
17	302244	1	Screw Block
18	302242	1	Pin
19	10303	4	O-ring

**Parts Included but Not Shown**

216819	1	Made in USA Decal
--------	---	-------------------

## Safety Precautions



**Caution:** To prevent personal injury,



- If the operator cannot read and understand these operating instructions and safety precautions, they must be read and discussed in the operator's native language.



- Wear eye protection that meets the requirements of ANSI Z87.1 and OSHA.

- Do not attempt to lift a load that exceeds the maximum capacity of 6,000 lbs. / 2,720 kg. Overloaded equipment can fail and cause personal injury. To ensure the load bearing chains are not stressed beyond their capacities, do not adjust the load rotor to an angle greater than 30° (see Figure 2), and do not spread the load bearing chains more than a total of 90° for both chains (see Figure 3).

- Secure all adjusting bolts before lifting a load.

- Attach BOTH arms to the load being lifted; do NOT use a single arm setup.



- The load rotor is not designed for overhead lifting applications. Stay out from underneath a load being lifted or suspended.

## Operating Instructions

The Load Rotor is designed to handle and position large, bulky components. The horizontal tilt can be adjusted to compensate for off-center loads, or adjusted to a certain angle for a component being positioned.

1. Hook the load rotor to a crane or hoist.
2. Attach the two load bearing chains to the component. Adjust the extension arms in or out to keep the chain angle at a minimum.
3. Verify the bolts holding the extension arms are securely fastened. See Figure 1.

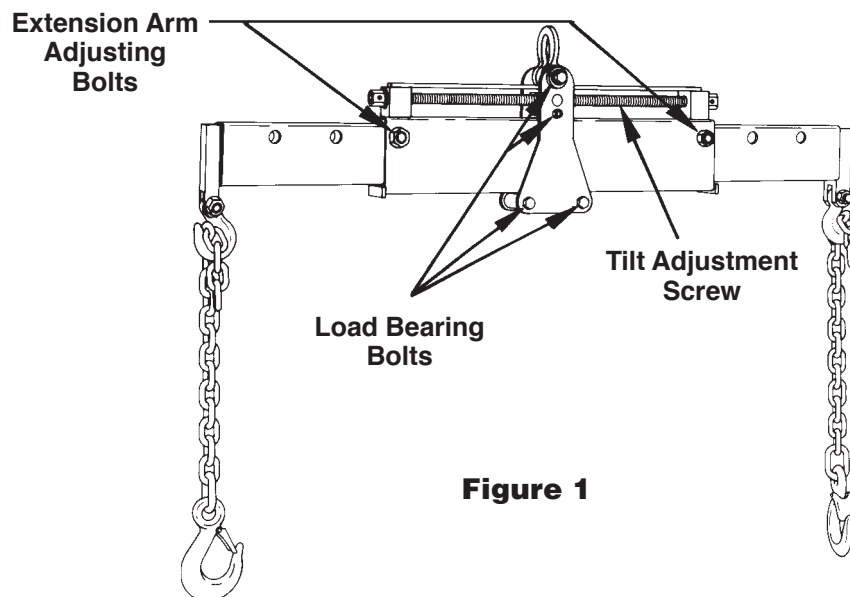

**Figure 1**

*Continued on back . . .*

## Operating Instructions Continued. . .

**⚠ Caution:** To maintain stability and ensure the load bearing chains are not stressed beyond their capacities,

- Do not adjust the load rotor to an angle greater than 30°. See Figure 2.
  - Do not spread the load bearing chains more than a total of 90° for both chains. See Figure 3.
4. Lift the component enough to locate the center of balance. Level or adjust the angle of the load rotor by using a wrench to turn either end of the threaded adjustment screw.

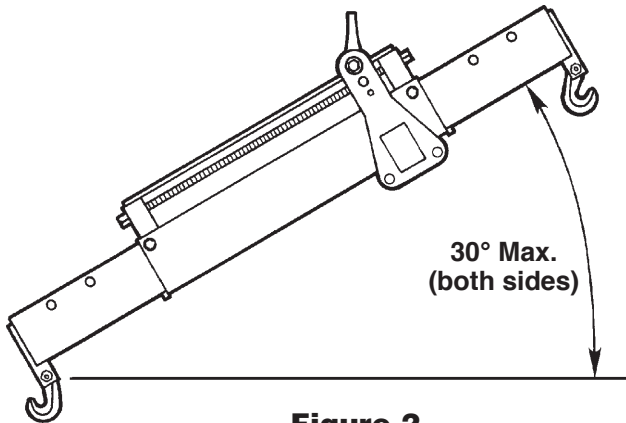
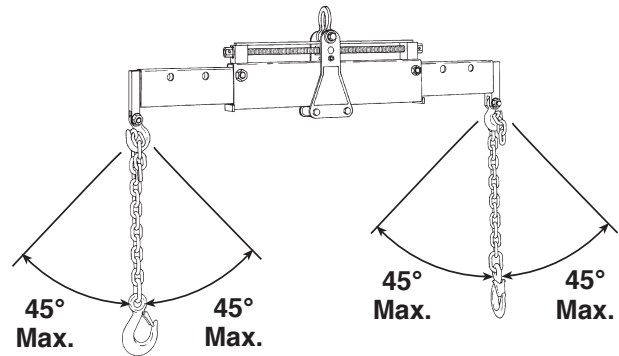
**Figure 2****Figure 3**

## Maintenance

1. Regularly clean and lubricate the tilt adjustment screw. See Figure 1.
2. Keep the four load bearing bolts fastened securely. See Figure 1.