



655 Eisenhower Drive  
Owatonna, MN 55060 USA  
Phone: (507) 455-7000  
Tech. Serv.: (800) 533-6127  
Fax: (800) 955-8329  
Order Entry: (800) 533-6127  
Fax: (800) 283-8665  
International Sales: (507) 455-7223  
Fax: (507) 455-7063

Form No. 102576

Operating Instructions for:

1823	1824A
1823A	309110
1824	309111

## Shop Press

Maximum Capacity: 12 Tons and 20 Tons

These instructions are intended for various shop presses. Some models are shipped assembled and require a minor amount of assembly; others are shipped unassembled and require complete assembly. The complete assembly procedure is provided in the following instructions for your reference. Verify the contents of the shipping carton against the parts list provided to ensure all parts are present before beginning assembly.

### SAFETY PRECAUTIONS

 **WARNING:** To prevent personal injury;



- Read and carefully follow the operating instructions and safety precautions for the press and bottle jack. Most problems are caused by incorrect assembly or operation.
- The owner of the press must ensure the press is installed and operated according to Federal (OSHA), state, and local safety standards.

- A press can exert an extremely high force at a moderate hydraulic pump pressure. If you have any questions about how much force is exerted at a given pressure, contact Technical Services.
- This press is designed for shop maintenance applications. For use in other applications, contact Technical Services.

### OPERATION



- Wear eye protection that meets the standards of ANSI Z87.1 and OSHA. Keep hands away from the work area. The press should be located in an isolated area or shielded to minimize danger to others. Hydraulic pressure can cause materials to break, possibly resulting in personal injury.



- It is impossible for the manufacturer to provide practical, all-purpose shielding because this is a general purpose press used in many different applications. The owner of the press must supply shielding (such as the 1230PB or 2036PB available through OTC) that is practical and specific for a particular application.

- A workpiece must be well supported and aligned to prevent slippage and breakage.
- To prevent accidental slippage, do not place workpiece on the press bed or apply hydraulic force until all bolster pins are in place and all tension has been removed from the bolster lift cables.
- Do not stress adapters beyond their capacities. Pushing or pulling adapters used with this press must have a maximum tonnage rating equal to, or greater than, the maximum tonnage rating of the press. Otherwise, breakage may occur.
- The user must ensure all safety-related decals are installed, maintained, and replaced when necessary.

Sheet No. 1 of 1

Issue Date: Rev. E, June 25, 2014

### Assembly Instructions

1. With the left and right uprights placed horizontally on the floor, bolt the upper bolster to both uprights using  $\frac{5}{8}$ -11 x  $1\frac{1}{4}$ -in. cap screws and  $\frac{5}{8}$ -11 nuts.
2. Slide the lower bolster onto the uprights.
3. Bolt the two straps to the uprights using  $\frac{1}{2}$ -13 x  $1\frac{1}{4}$ -in. cap screws and  $\frac{1}{2}$ -13 nuts.
4. Bolt an angle foot to each upright using  $\frac{1}{2}$ -13 x  $1\frac{1}{4}$ -in. cap screws, washers, and  $\frac{1}{2}$ -13 nuts. *Note: The 20 ton press uses flat washers on the slots in the angle foot.*

**⚠ WARNING:** To prevent personal injury while performing the next step, use an overhead crane (or similar lifting device) to lift the shop press assembly off the floor and into its standing, upright position.

5. Lift the press to its standing, upright position.
6. Slide the lower bolster up to the mid-point position of the upright assembly and install two bolster pins to secure the bolster.
7. Insert the pressing bracket through the holes in the upper bolster. Then place a spring and washer on each tube of the pressing bracket and install a roll pin through each tube to secure the washer and spring. *Note: Use the top holes in the pressing bracket tubes for a 20-ton press; use the lower holes for a 12-ton press.*
8. Use the set screw provided to secure the pressing pin to the bottom of the pressing bracket.
9. Slide the pressing bracket downward and install the bottle jack in its normal upright position. The saddle on the end of the bottle jack extension screw must nest in the round hole in the guide plate along the bottom of the bolster. The pump handle receiver and the pump release valve must face out, as shown.

**12 Ton Press:** Install roll pin in lower holes (as shown).  
**20 Ton Press:** Install roll pin in upper holes.

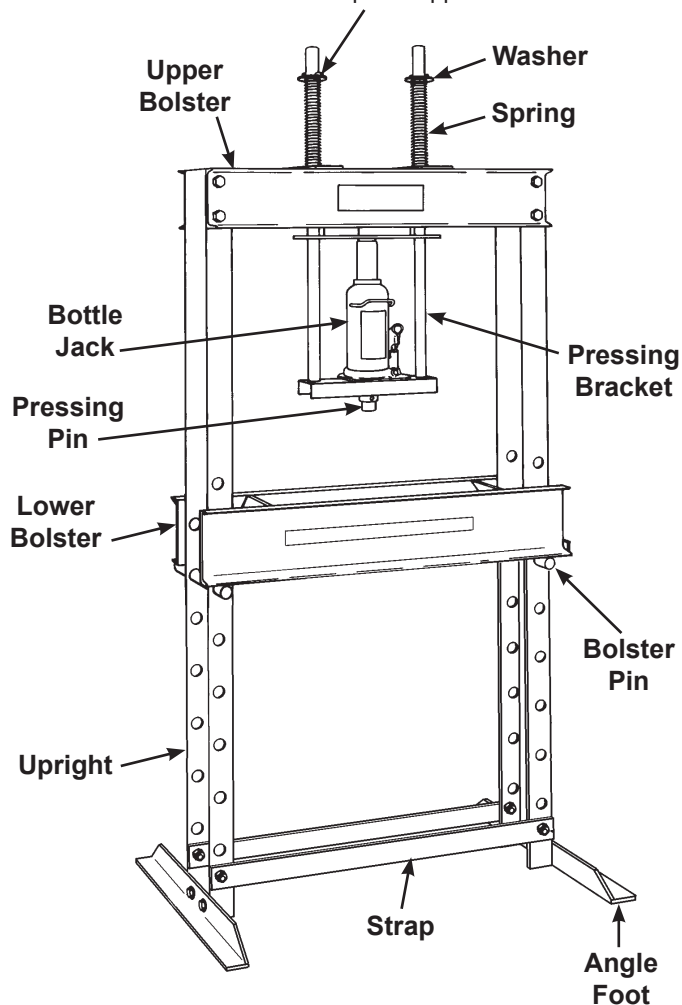

### Operating Instructions

1. Tightly close the release valve on the bottle jack, by turning it clockwise.
2. Insert the bottle jack handle into the receiver and start pumping the jack. To release pressure and lower the jack, slowly turn the release valve counterclockwise. *Note: A notch in the end of the jack handle can be used to turn the release valve.*

**To adjust the lower bolster,** hold one end of the lower bolster in place and adjust the bolster pin up or down, one or two holes. Then hold in place the other end of the bolster and adjust its associated bolster pin so the lower bolster is level.

**To change press adapters,** unscrew the set screw in the pressing bracket sleeve. Remove the adapter, and insert the desired adapter, seating it completely. Tighten the set screw.