



SPX Corporation  
 655 Eisenhower Drive  
 Owatonna, MN 55060-0995 USA  
 Phone: (507) 455-7000  
 Tech. Serv.: (800) 533-6127  
 Fax: (800) 955-8329  
 Order Entry: (800) 533-6127  
 Fax: (800) 283-8665  
 International Sales: (507) 455-7223  
 Fax: (507) 455-7063

Form No. 106511

Parts List &  
 Operating Instructions for: **1517A**  
**1519A**

## Collision Repair Set

### No. 1517A 4-Ton Set

Item No.	Part No.	Description
1	222524	Storage Case
2	4082A	Ram w/Half Coupler
3	222618	6 ft. Hose w/male 1/4" NPT Fittings
4	4000	Hydraulic Hand Pump
5	222523	Flex Head
6	9101A	Spreader w/Ram Half Coupler
7	222520	Wedge Head
8	222519	90° V-base
9	222517	Serrated Saddle
10	222521	Plunger Toe
11	222518	Flat Base
12	528841	Spreader Toe (1 <sup>1</sup> / <sub>2</sub> "-18)
13	222516	Extension Tube Coupling
14	222515	4" Extension
15	222512	16" Extension
16	222513	12" Extension
17	222514	8" Extension
18	504888	Hose Half Coupler
	10676	Straight Fitting (not shown; for pump)

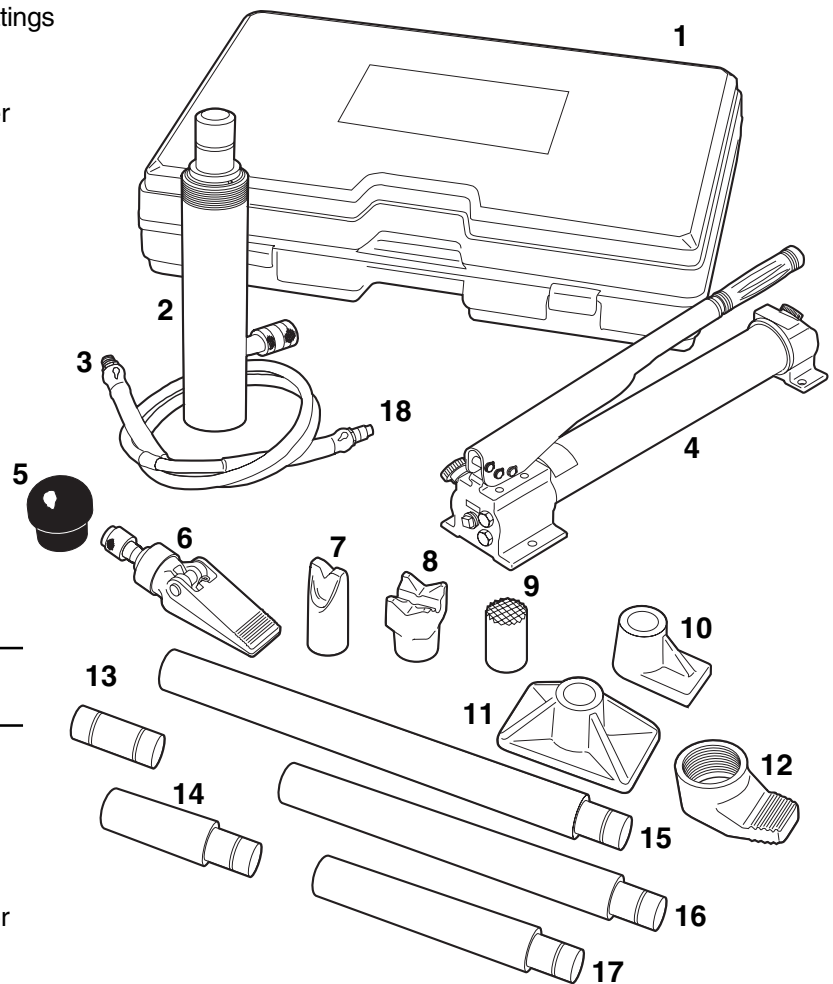

### No. 1519A 10-Ton Set

Item No.	Part No.	Description
1	222538	Storage Case
2	4083B	Ram w/Half Coupler
3	222618	Hose Assembly
4	4004	Hydraulic Hand Pump
5	222537	Flex Head
6	9101A	Spreader w/Ram Half Coupler
7	222534	Wedge Head
8	222533	90° V-base
9	222531	Serrated Saddle
10	222535	Plunger Toe
11	222532	Flat Base
12	222536	Spreader Toe (2 <sup>1</sup> / <sub>4</sub> "-14)
13	222530	Extension Tube Coupling
14	222529	5" Extension
15	222526	19" Extension
16	222527	14" Extension
17	222528	10" Extension
18	504888	Hose Half Coupler
	10676	Straight Fitting (not shown)
	512702	Wheel/Axle Kit (not shown)

Shaded area indicates last revision made to this form.

Sheet No. 1 of 3

Issue Date: Rev. E, April 12, 2005

## Safety Precautions

**⚠ CAUTION:** Failure to heed the following precautions may result in loss of load, damage or failure of equipment, resulting in property damage and / or personal injury.



- Read, understand, and follow all safety precautions and instructions included with the set. If the operator cannot read English, operating instructions and safety precautions must be read and discussed in the operator's native language.

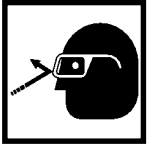

- The owner of this set is responsible for it being installed and operated according to federal (OSHA), state, and local safety standards.
- Safety-related decals must be installed, maintained, and replaced if they become hard to read.
- Wear eye protection that meets ANSI Z87.1 and OSHA standards.
- This equipment is designed for vehicle body / frame applications. Using this equipment in an application for which it is not designed could result in overloading, reduced load capacity, reduced stability, and / or system failure.

- Do not overload the hydraulic system; creating pressure beyond the rated capacity of the pump and ram may result in personal injury. Overloading is indicated by bowing extension tubes or slipping attachments.
- Some components in this set do not match the maximum pressure rating of the pump and ram. **USE A PRESSURE GAUGE IN THE SYSTEM TO MONITOR HYDRAULIC PRESSURE.** Refer to the instructions in this document for *Typical Applications and Load Capacities*.
- Attachments and extension tubes must be aligned and fully engaged so ram force is straight, avoiding an off-center load condition.

### Hose



- Before operating the pump, tighten all hose connections using the correct tools. Do not overtighten; connections need only be secure and leak-free. Overtightening can cause premature thread failure or high pressure fittings to split at pressures lower than their rated capacities.
- Should a hydraulic hose ever rupture, burst, or need to be disconnected, immediately shut the pump OFF, and open the control valve to release all pressure. **NEVER** grasp a leaking, pressurized hose with your hands; the force of escaping hydraulic fluid could cause serious injury.
- Do not subject the hose to any potential hazard such as fire, extreme cold or heat, sharp surfaces, or heavy impact. Do not allow the hose to kink, twist, curl, or bend so tightly that the fluid flow within the hose is blocked or reduced. Do not use the hose to move attached equipment. Periodically inspect the hose for wear, because any of these conditions can damage the hose and result in personal injury.
- Hose material and coupler seals must be compatible with the hydraulic fluid used. Hoses also must not come in contact with corrosive materials, such as creosote-impregnated objects and some paints. Consult the manufacturer before painting a hose. Never paint couplers. Hose deterioration due to corrosive material can result in personal injury.

### Pump



- Do not exceed the maximum capacity of the pump or tamper with the internal high pressure relief valve. Creating pressure beyond the rated capacity can result in personal injury.
- Completely retract the ram before opening the filler screw on the pump to add hydraulic fluid. An overfill can cause personal injury due to excess reservoir pressure created when rams are retracted.

### Ram

- Do not exceed the maximum capacity of the ram. Creating pressure beyond the rated capacity can result in personal injury.
  - Do not set poorly-balanced or off-center loads on a ram. The load may tip and cause personal injury.
- If you have any questions concerning an application, or how much force is exerted at a given pressure, please contact Technical Services at (800) 533-6127.

If you have any questions concerning an application, or how much force is exerted at a given pressure, please contact Technical Services at (800) 533-6127.

## Operating Instructions

### Setup

The pump may be operated in a horizontal position or in a vertical position with the head pointing down.

1. Assemble the hose between the pump and ram.
2. Determine the appropriate attachment for your application; assemble the attachment to the ram piston.

#### IMPORTANT:

- **The use of extension tubes or off-center attachments greatly reduces the capacity of the hydraulic system. When using extension tubes, put the shortest tubes on the ends of the setup; never put the shortest tubes in the middle of the setup.**
- **Some components in this set do not match the maximum pressure rating of the pump and ram. USE A PRESSURE GAUGE IN THE SYSTEM TO MONITOR HYDRAULIC PRESSURE. Refer to the instructions in this document for *Typical Applications and Load Capacities*.**

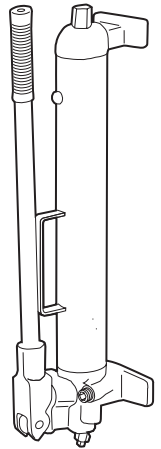

### Operation

1. Turn the pump's release valve clockwise to a closed position. **IMPORTANT: Hand tighten the valve only; applying too much force to the valve may damage the valve stem.**
2. Work the pump handle up and down to send oil through the hose to the ram, causing the piston to extend to the work piece.
3. Monitor the pressure gauge while completing the application.

**Note:** *The pump is equipped with an overload valve that will bypass oil back into the pump reservoir in an overload situation (when the system meets maximum pressure). In this case, continued pumping will have no effect on the system. If an overload situation commonly occurs, a higher capacity set is needed.*

4. To release pressure, slowly turn the release valve counterclockwise. (The release speed is controlled by how fast the valve is opened.)

### Bleeding Air from the System

Air can accumulate in the hydraulic system during the initial setup or after prolonged use, causing the ram to respond slowly or in an unstable manner. To remove the air:

1. Place the ram at a lower level than the pump, with the piston end pointing down.
2. Extend and retract the ram several times without putting a load on the system. Air will be released into the pump reservoir.
3. With the ram fully retracted, the pump sitting level, and no pressure in the hydraulic system, remove the pump's filler screw. Fill the reservoir with approved hydraulic fluid until the fluid level is within  $\frac{1}{2}$  inch (12.7 mm) from the top of the reservoir.

### Typical Applications and Load Capacities

When offset attachments are used, the rated capacity of the hydraulic system is reduced 50%. For each extension tube used in the setup, the rated capacity is reduced another 50%. When using two or more extension tubes together, always position the shortest tube farthest away from the ram.

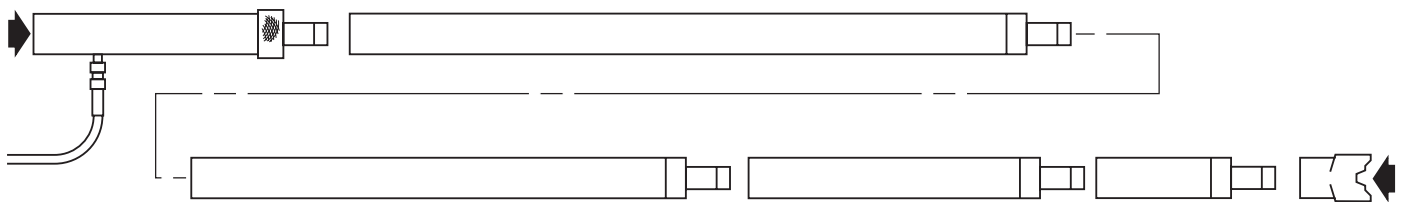
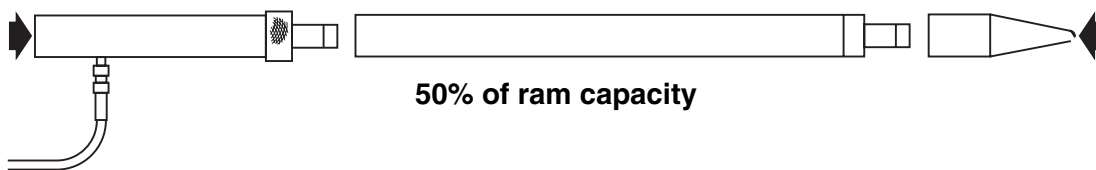
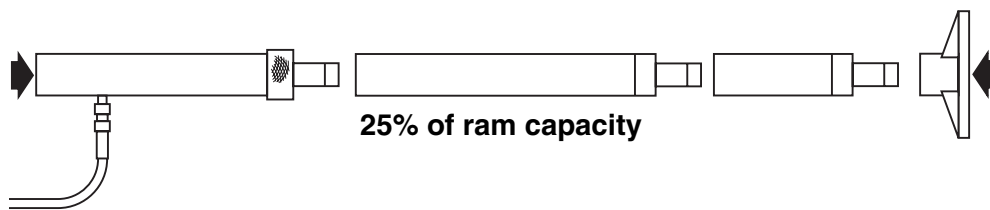
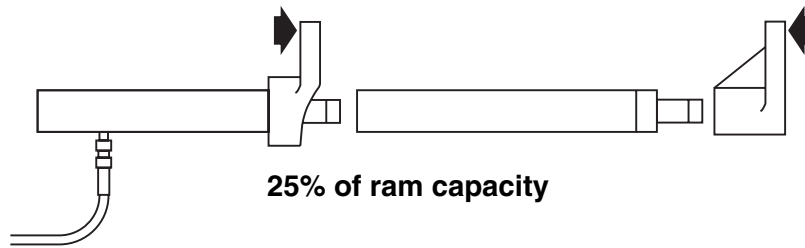
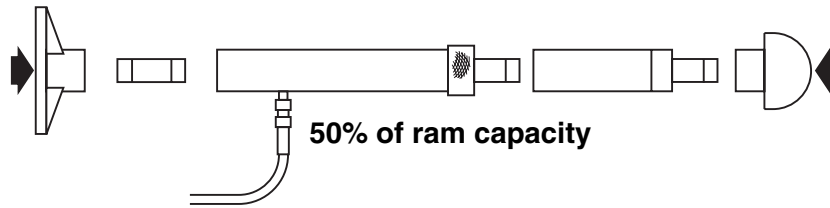
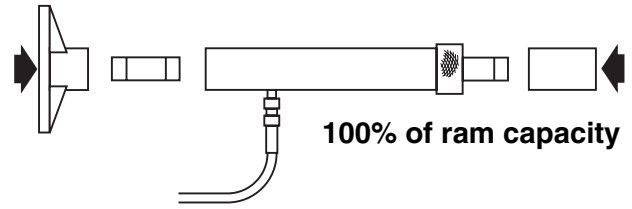
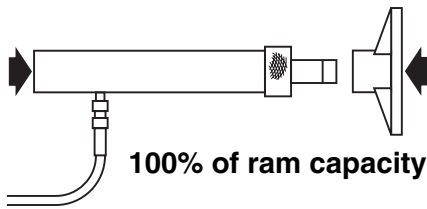
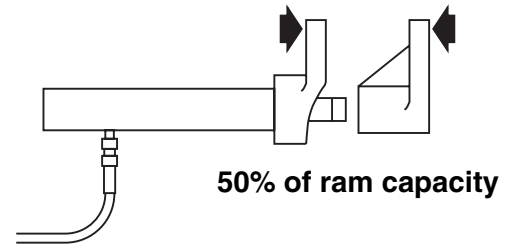

**Troubleshooting**



**CAUTION:** To prevent personal injury, release pump pressure and disconnect the hose from the pump before making repairs.

Repairs must be performed in a dirt-free environment by qualified personnel who are familiar with this equipment. If the following solutions do not remedy the problem, take the product to an authorized service center for repair.

<b>Problem</b>	<b>Cause</b>	<b>Solution</b>
<b>Pump loses pressure</b>	1. System components leaking.	1. <i>Repair or replace as necessary.</i>
<b>Pump not delivering fluid</b>	1. Low fluid level in reservoir. 2. Seats are worn.	1. <i>Check fluid level.</i> 2. <i>Repair seats or replace pump body.</i>
<b>Pump does not reach rated capacity</b>	1. Low fluid level in reservoir. 2. System components leaking. 3. Fluid leaking past inlet or outlet checks.	1. <i>Check fluid level.</i> 2. <i>Repair or replace as necessary.</i> 3. <i>Repair inlet or outlet checks, or replace high pressure piston seal.</i>
<b>Pump handle has a “spongy” feel</b>	1. Air trapped in system. 2. Too much fluid in reservoir.	1. <i>Refer to <u>Bleeding Air from the System</u>.</i> 2. <i>Check fluid level.</i>
<b>Ram piston will not extend</b>	1. Loose couplers. 2. Low fluid level in pump reservoir. 3. Ram seals leaking.	1. <i>Tighten couplers.</i> 2. <i>Fill and bleed the system.</i> 3. <i>Replace worn seals. Look for excessive contamination or wear.</i>
<b>Ram piston extends only partially</b>	1. Low fluid level in pump reservoir. 2. Load is above capacity of system.	1. <i>Fill and bleed the system.</i> 2. <i>Use correct equipment.</i>
<b>Ram piston extends slower than normal</b>	1. Loose couplers. 2. Restricted hydraulic line or fitting. 3. Pump not working correctly. 4. Ram seals leaking.	1. <i>Tighten couplers.</i> 2. <i>Clean and replace if damaged.</i> 3. <i>Repair or replace as necessary.</i> 4. <i>Replace worn seals. Look for excessive contamination or wear.</i>
<b>Ram does not hold pressure</b>	1. Leaky connection.  2. Ram seals leaking.  3. Pump or valve not working correctly.	1. <i>Clean, reseal with thread sealant, and tighten connection.</i> 2. <i>Replace worn seals. Look for excessive contamination or wear. Replace contaminated fluid.</i> 3. <i>Repair or replace as necessary.</i>
<b>Ram leaks hydraulic fluid</b>	1. Worn or damaged seals.  2. Loose connection.	1. <i>Replace worn seals. Look for excessive contamination or wear. Replace contaminated fluid.</i> 2. <i>Clean, reseal with thread sealant, and tighten connection.</i>
<b>Ram will not retract or retracts slower than normal</b>	1. Pump release valve closed. 2. Loose couplers. 3. Blocked hydraulic lines. 4. Weak or broken retraction springs. 5. Ram damaged internally. 6. Pump reservoir too full.	1. <i>Open pump release valve.</i> 2. <i>Tighten couplers.</i> 3. <i>Clean and flush lines.</i> 4. <i>Send to service center for repair.</i> 5. <i>Send to service center for repair.</i> 6. <i>Drain fluid to correct level.</i>