



SPX Corporation
655 Eisenhower Drive
Owatonna, MN 55060-0995 USA
Phone: (507) 455-7000
Tech. Serv.: (800) 533-6127
Fax: (800) 955-8329
Order Entry: (800) 533-6127
Fax: (800) 283-8665
International Sales: (507) 455-7223
Fax: (507) 455-7063

Form No. 107241

**Parts List &
Assembly Instructions**

for:

5100

Wheel Mate™ Assembly Instructions

Use the following steps to assemble the Wheel Mate:

1. Connect the lower main frame to the main rear upright support using two 3/8" x 3-1/4" bolts, four 3/8" flat washers, and two 3/8" lock nuts.

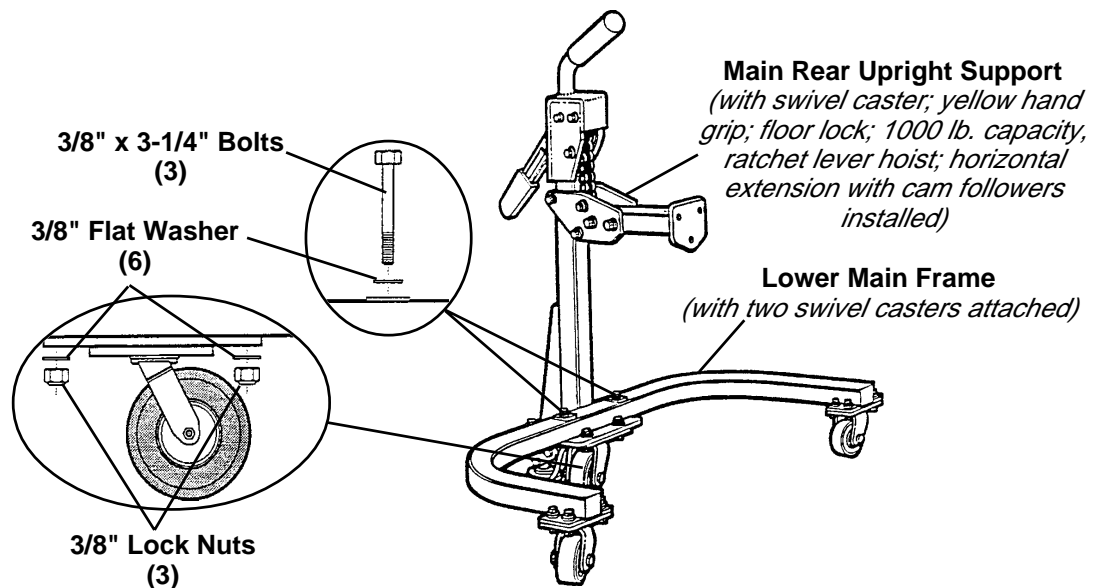

Note: The number of parts included in the Wheel Mate assembly kit are identified in parenthesis on the illustrations. Parts not identified with a number are single units.

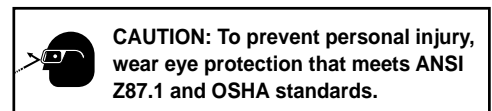

Sheet No. 1 of 2

Issue Date: Rev. B, June 15, 2006

2. Connect the main tire support ring to the lower tire support using two 5/16" x 1-3/4" bolts, four 5/16" flat washers, and two 5/16" lock nuts.

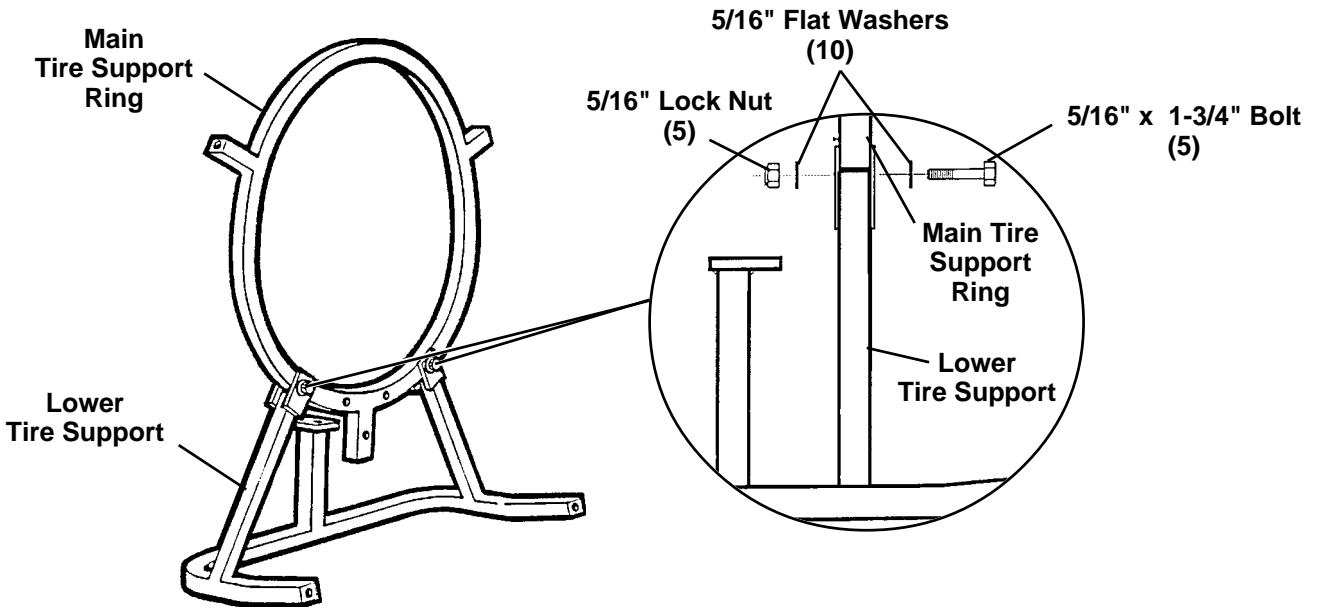

3. Connect the main tire support ring / lower tire support assembly to the horizontal slider plate using three 5/16" x 1-3/4" bolts, six 5/16" flat washers, and four 5/16" lock nuts.

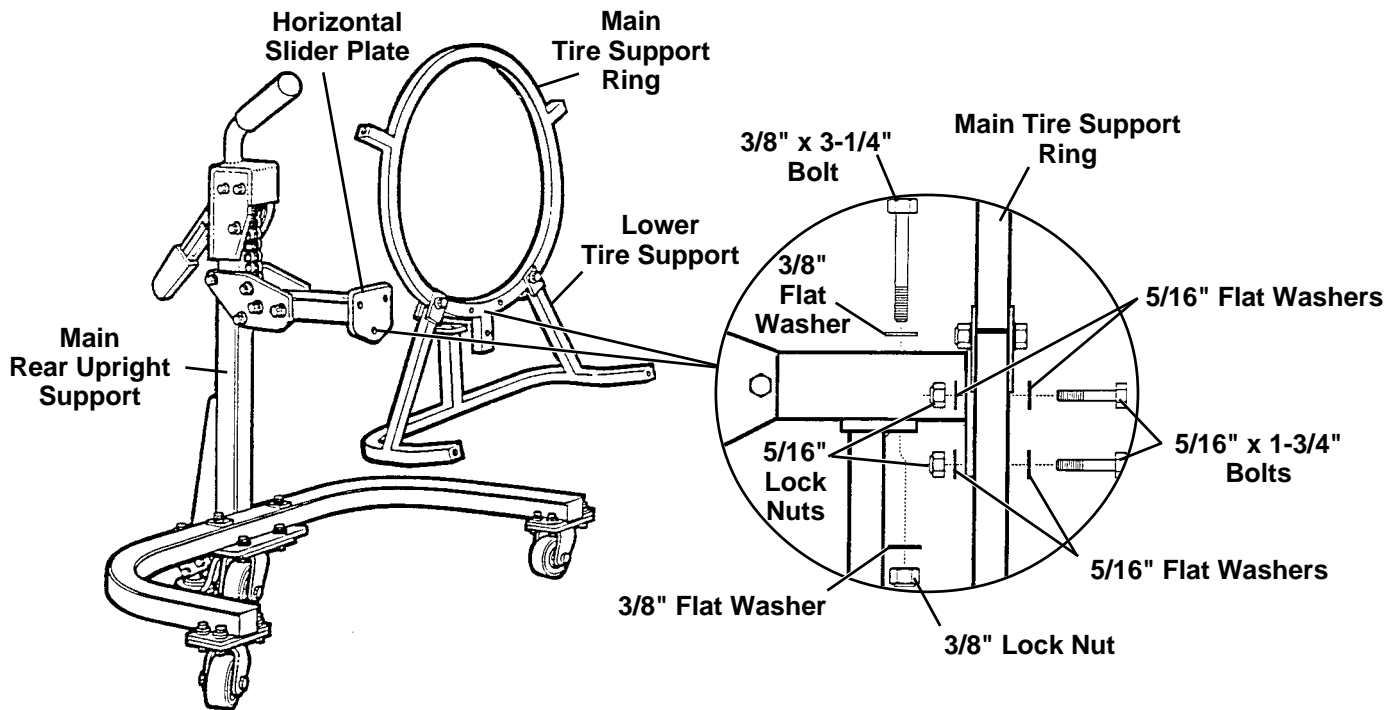

4. Secure the main tire support ring / lower tire support assembly to the horizontal slider plate using a 3/8" x 3-1/4" bolt, two 3/8" flat washers, and a 3/8" lock nut.

- Install three 4-1/2" upper rollers to the main tire support ring using three 1/2" x 6-1/2" roller studs with pre-installed crown acorn nuts, and three 11/16" stainless steel bushings. Do not overtighten studs; roller will not spin freely if studs are too tight.

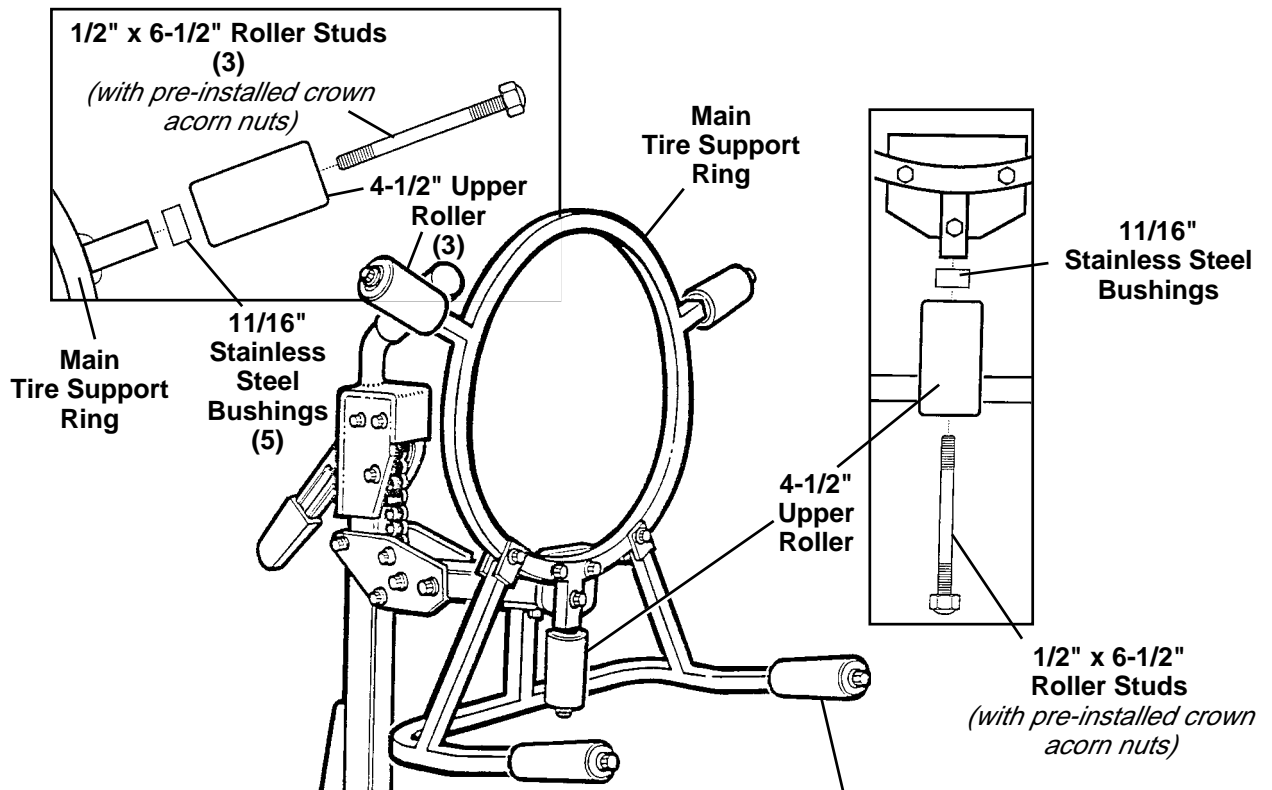

- Install two 8-3/4" upper rollers to the lower tire support using two 1/2" x 11" roller studs with pre-installed crown acorn nuts and three 11/16" stainless steel bushings. Do not overtighten studs; roller will not spin freely if studs are too tight.

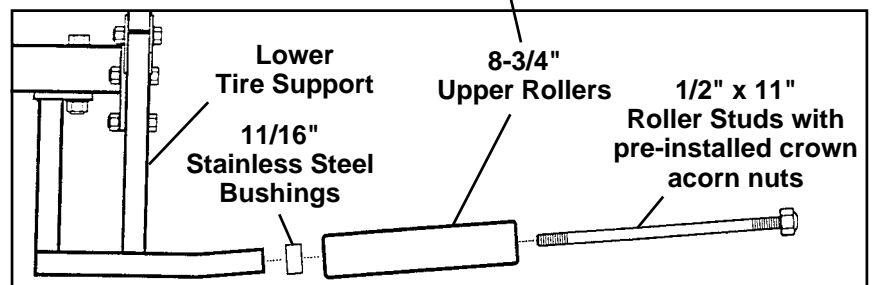

Assembled Unit and Repair Parts:

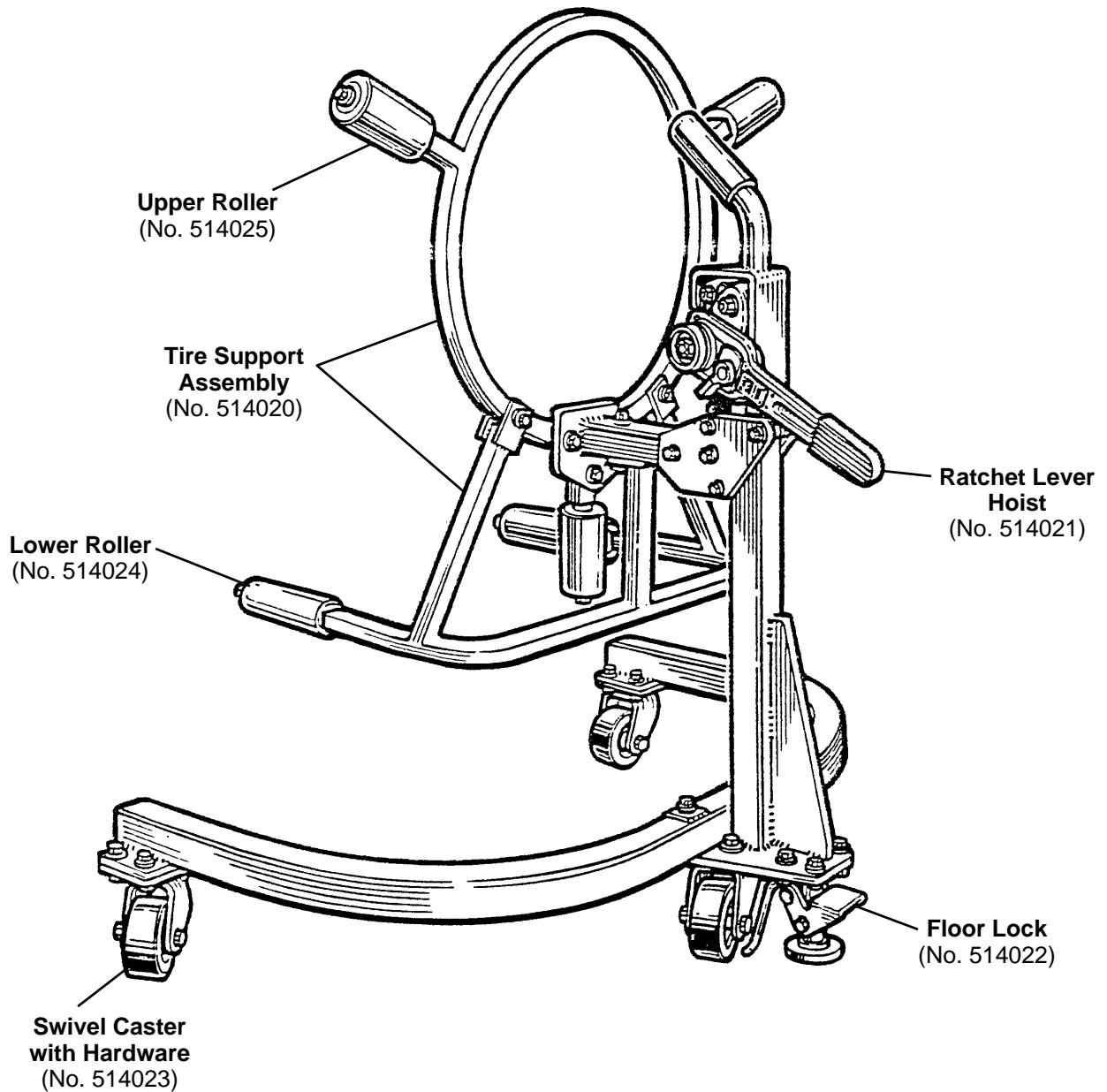

Replacement Parts

Item No.	Description
514020	Tire Support Assembly
514021	Ratchet Lever Hoist
514022	Floor Lock
514023	Swivel Casters
514024	1.9" O.D. x 8.75" Lower Roller
514025	2.375" O.D. x 4.5" Upper Roller