



655 Eisenhower Drive
 Owatonna, MN 55060 USA
 Phone: (507) 455-7000
 Tech. Serv.: (800) 533-6127
 Fax: (800) 955-8329
 Order Entry: (800) 533-6127
 Fax: (800) 283-8665
 International Sales: (507) 455-7223
 Fax: (507) 455-7063

Form No. 524675

**Parts List &
 Operating Instructions**
 for:

1822

Load-Rotor®

Max. Capacity: 10,000 lbs. / 4,540 kg

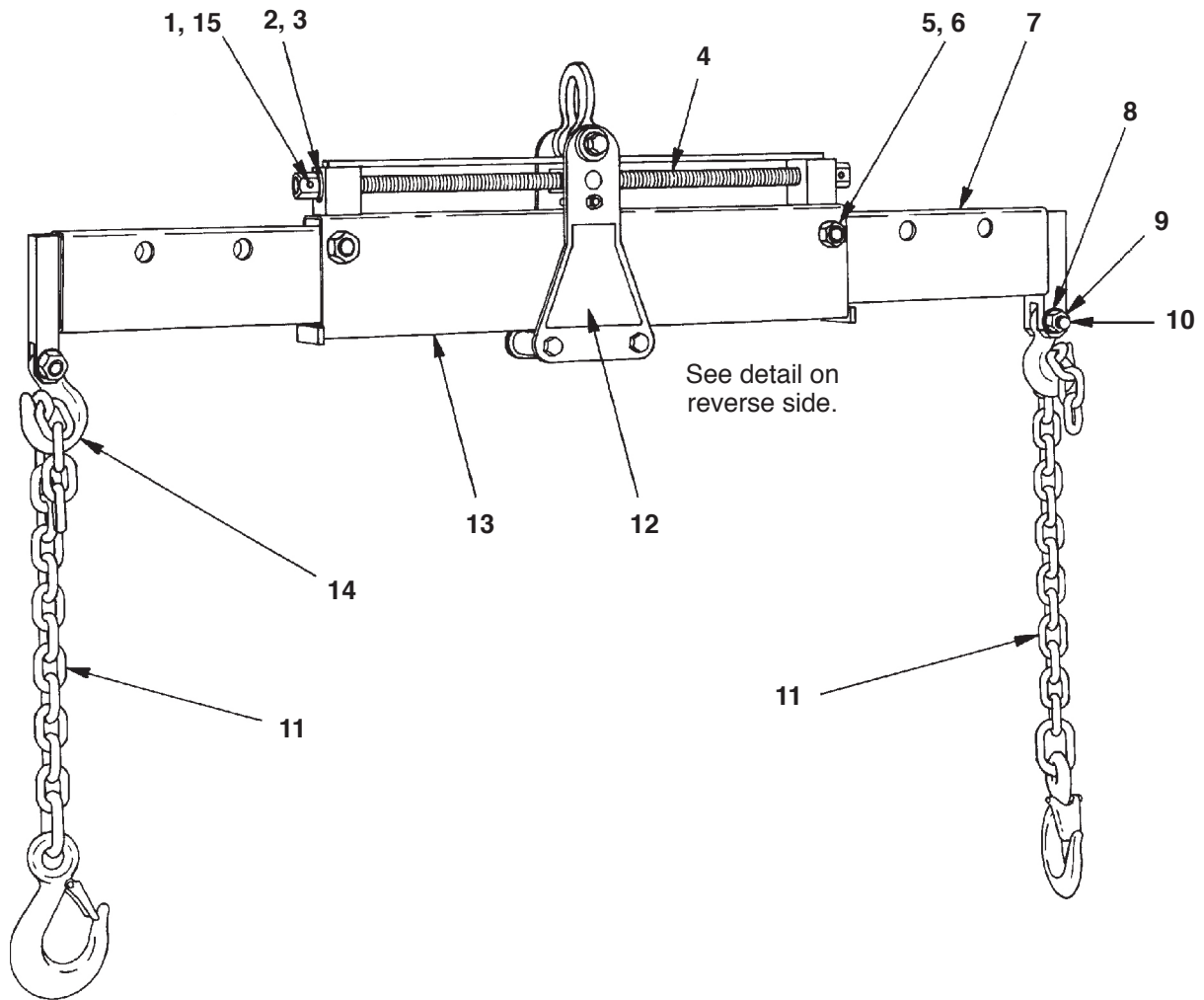

Item No.	Part No.	No. Req'd	Description
1	10585	2	Roll Pin
2	206746	2	Thrust Bearing
3	16209	4	Thrust Washer
4	303449	1	Screw
5	19340	2	Hex Hd. Cap Screw (3/4-10 x 4" Lg.)
6	10216	2	Hex Nut (3/4-10)
7	52013	2	Inner Tube (includes items 9, 10, 11, & 15)
8	13324	4	Washer (for 5/8" bolt)
9	10213	2	Hex Nut (5/8-18)

Item No.	Part No.	No. Req'd	Description
10	22045	2	Hex Hd. Cap Screw (5/8-18 x 2-1/2" Lg.)
11	302249	2	Chain & Safety Hook
12	303471	1	Warning Decal
13	61039-WH2	1	Main Tube
14	16051	2	Eye Grab Hook
15	10481	2	Roll Pin
Parts Included but Not Shown			
	304525	2	Capacity Decal

Sheet No. 1 of 2

Issue Date : Rev. D, December 11, 2017

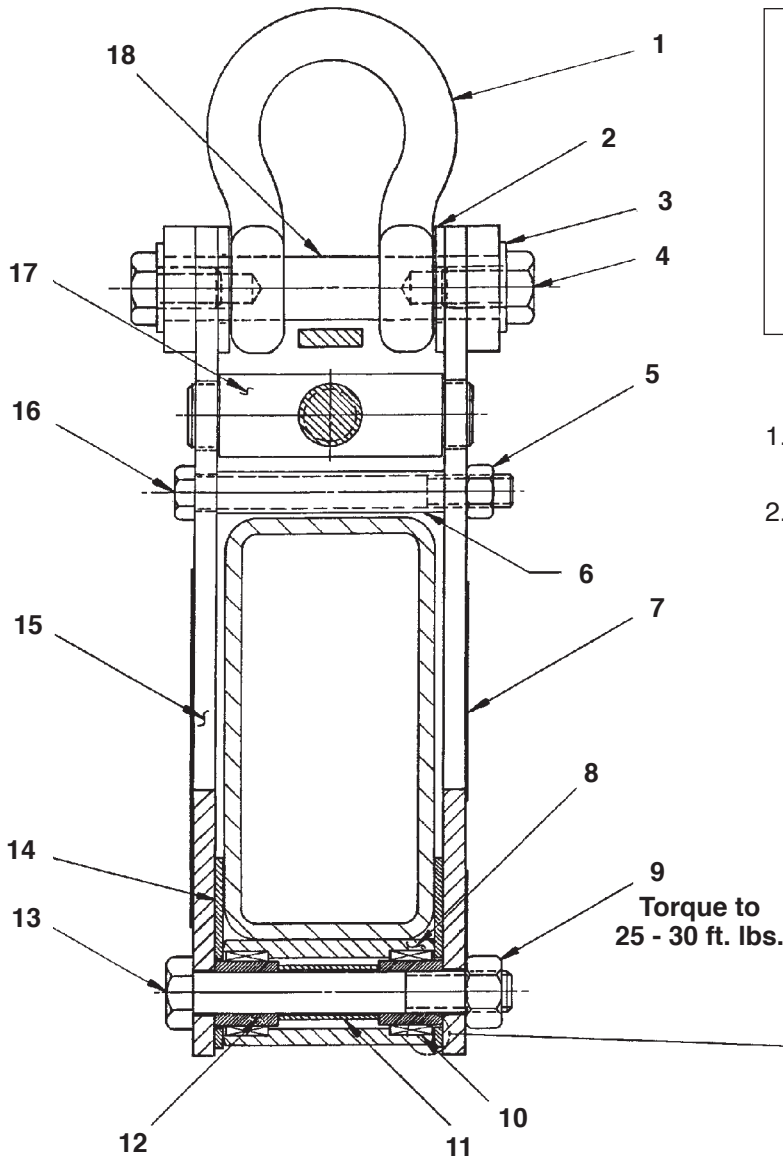

Refer to any operating instructions included with the product for detailed information about operation, testing, disassembly, reassembly, and preventive maintenance.

Items found in this parts list have been carefully tested and selected by OTC. **Therefore: Use only OTC replacement parts!**

Additional questions can be directed to the OTC Technical Services Department.

Maintenance

1. Regularly clean and lubricate the tilt adjustment screw. See Figure 1.
2. Keep the four load bearing bolts fastened securely. See Figure 1.

Note: Grease bearings (Item 10) before assembly.

Item No.	Part No.	No. Req'd	Description
1	208112	1	Anchor Shackle
2	208149	2	Spacer (for 3/4" bolt)
3	12004	2	Washer (for 1/2" bolt)
4	10075	2	Hex Hd. Cap Screw (1/2-13 x 3/4" Lg.)
5	207255	1	Hex Nut (1/2-13)
6	208110	1	Spacer
7	524674	1	Trade Name Decal
8	303452	2	Roller
9	12726	2	Locknut (5/8-18; torque to 25-30 ft. lbs.)

Item No.	Part No.	No. Req'd	Description
10	208087	4	Needle Bearing
11	208111	2	Spacer
12	208088	4	Inner Bearing Race
13	10465	2	Hex Hd. Cap Screw (5/8-18 x 4-1/2" Lg.)
14	303451	2	Wear Pad
15	52015	2	Side Plate
16	10094	1	Hex Hd. Cap Screw (1/2-13x 4-1/2" Lg.)
17	44937	1	Screw Block
18	303450	1	Pin

Safety Precautions



Caution: To prevent personal injury,



- Wear eye protection that meets the requirements of ANSI Z87.1 and OSHA.



- Read, understand, and follow all instructions and safety precautions included with the Load Rotor®. If the operator cannot read English, operating instructions and safety precautions must be read and discussed in the operator's native language.



- Secure all adjusting bolts before lifting a load.
- Attach BOTH lift arms to the load being lifted; do NOT use a single arm setup.
- Do not attempt to lift a load that exceeds the maximum capacity of 10,000 lbs. / 4,540 kg. Overloaded equipment can fail and cause personal injury. To ensure the load bearing chains are not stressed beyond their capacities, do not adjust the load rotor to an angle greater than 30° (see Figure 2), and do not spread the load bearing chains more than a total of 90° for both chains (see Figure 3).
- The load rotor is not designed for overhead lifting applications. Stay out from underneath a load being lifted or suspended.

Operating Instructions

The Load Rotor is designed to handle and position large, bulky components. The horizontal tilt can be adjusted to compensate for off-center loads, or adjusted to a certain angle for a component being positioned.

1. Hook the load rotor to a crane or hoist.
2. Attach the two load bearing chains to the component. Adjust the extension arms in or out to keep the chain angle at a minimum.
3. Verify the bolts holding the extension arms are securely fastened. See Figure 1.



Caution: To maintain stability and ensure the load bearing chains are not stressed beyond their capacities,

- Do not adjust the load rotor to an angle greater than 30°. See Figure 2.
 - Do not spread the load bearing chains more than a total of 90° for both chains. See Figure 3.
4. Lift the component enough to locate the center of balance. Level or adjust the angle of the load rotor by using a wrench to turn either end of the threaded adjustment screw.

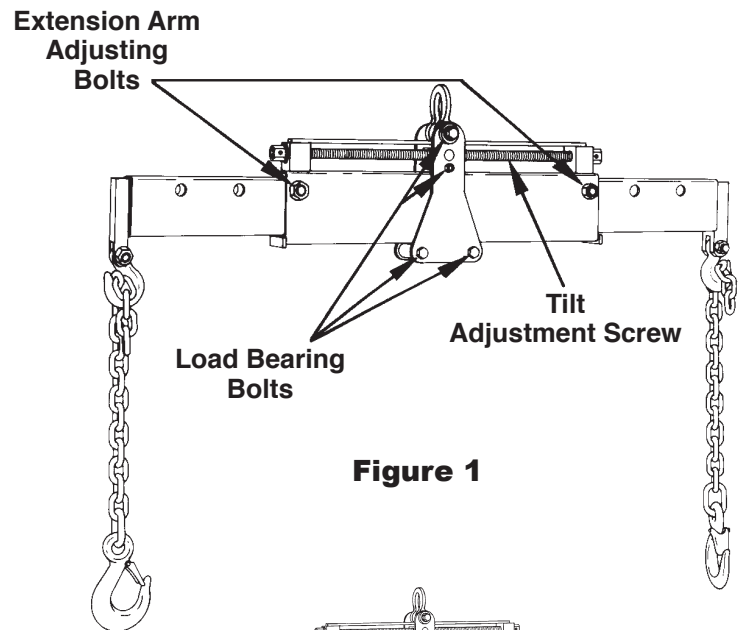

Figure 1

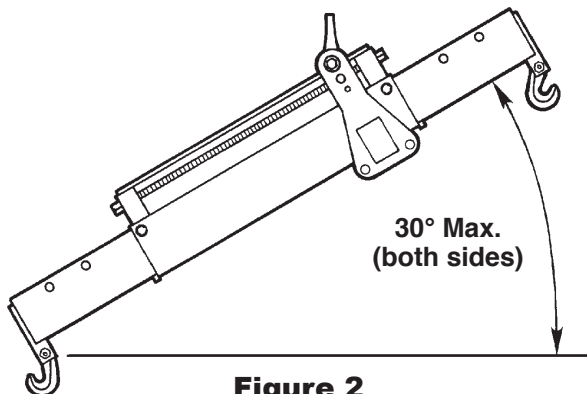

Figure 2

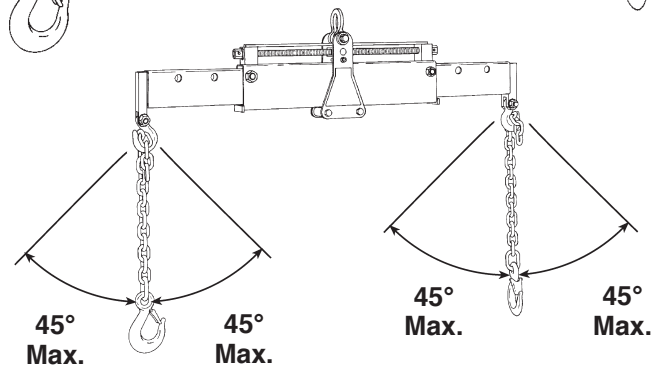

Figure 3

