

# Ford Rear Crankshaft Seal Installer

Applications : 1993-'97 Aerostar;  
1993-'04 Ranger and Explorer w/ 4.0L V6 engine

*Crankshaft rear oil seals used on the above vehicles  
are available with or without a metal wear sleeve;  
tool No. 7834 will work on both types.*

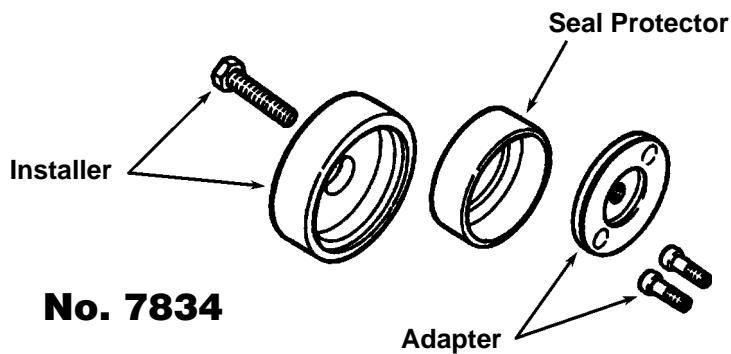

**No. 7834**



**CAUTION :** To prevent personal injury, wear eye protection that meets ANSI Z87.1 and OSHA standards.

1. Remove the old rear crankshaft seal (and wear ring, if applicable), and clean the crankshaft sealing surface.
2. Attach the adapter (from No. 7834) to the crankshaft using the supplied bolts. See Figure 1.
3. Install the new seal as shown in Figure 2:

### Seal with Wear Sleeve

*Note: If the new rear crankshaft seal includes a wear sleeve, do NOT remove it. Install the seal and wear sleeve together.*

- A. Lightly oil the crankshaft and the adapter assembled in Step 2.
- B. Place the seal & wear sleeve assembly on the adapter.
- C. Place the installer over the seal/wear sleeve, and install the bolt.

### Seal without Wear Sleeve

- A. Place the seal protector over the adapter assembled in Step 2.
  - B. Lightly oil the seal protector.
  - C. Place the seal on the seal protector.
  - D. Place the installer over the seal, and install the bolt.
4. Tighten the bolt on the installer to pull the seal assembly over the crankshaft and into the cylinder block. See Figures 3 and 4. **IMPORTANT :** To prevent damage to the seal, do not use air tools to pull the seal into place.
  5. Remove the installer, protector, and adapter.

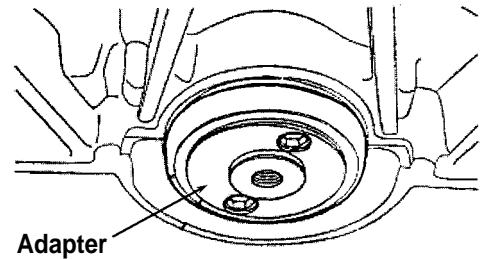

**Figure 1**

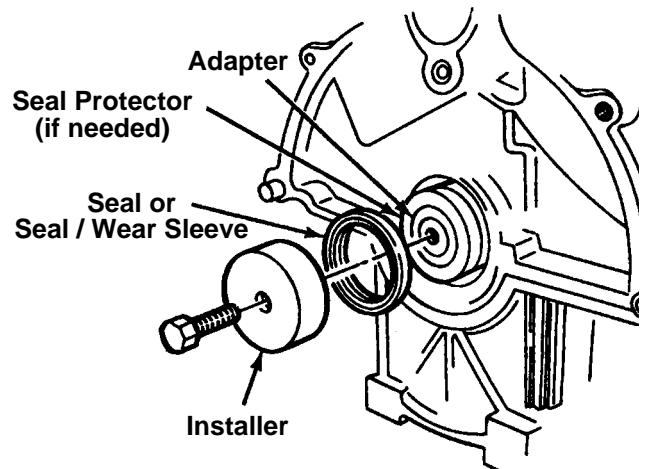

**Figure 2**

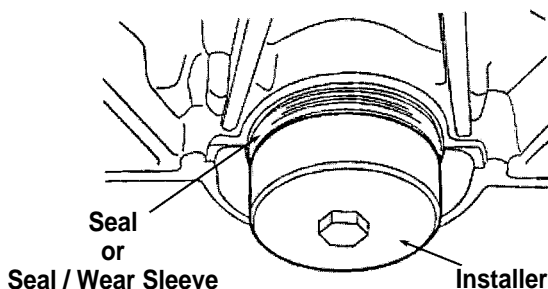

**Figure 3**

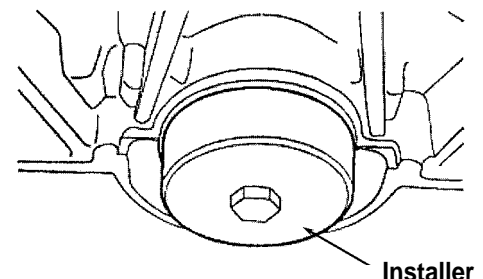

**Figure 4**