



SPX Corporation  
 655 Eisenhower Drive  
 Owatonna, MN 55060-0995 USA  
 Phone: (507) 455-7000  
 Tech. Serv.: (800) 533-6127  
 Fax: (800) 955-8329  
 Order Entry: (800) 533-6127  
 Fax: (800) 283-8665  
 International Sales: (507) 455-7223  
 Fax: (507) 455-7063

Form No. 548878

**Parts List &  
 Operating Instructions**  
 for:

**5018A**

Heavy-Duty Truck  
**Clutch and Flywheel Handler**

Max. Capacity: 300 lbs.

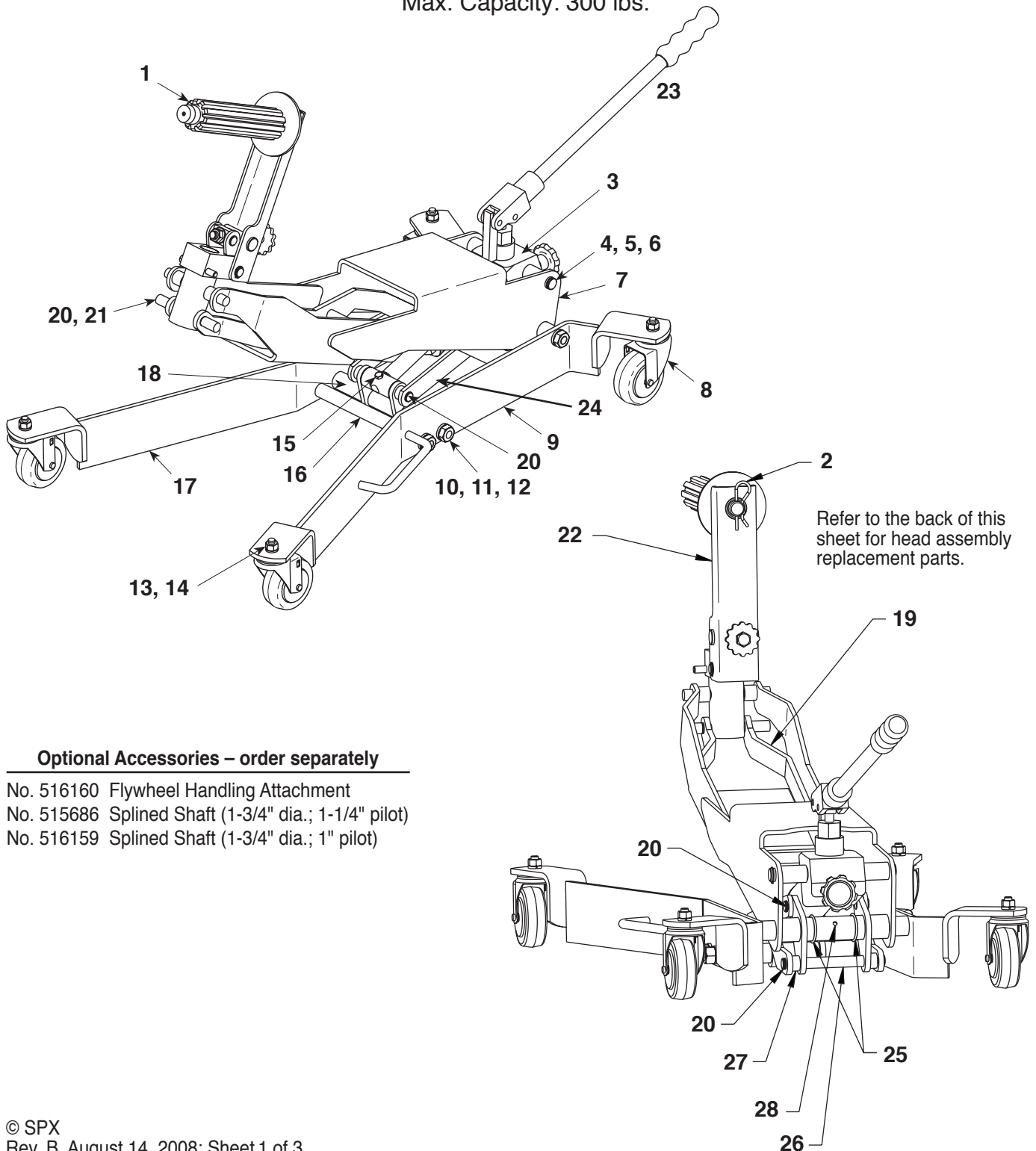

**Optional Accessories – order separately**

- No. 516160 Flywheel Handling Attachment
- No. 515686 Splined Shaft (1-3/4" dia.; 1-1/4" pilot)
- No. 516159 Splined Shaft (1-3/4" dia.; 1" pilot)

Item No.	Part No.	Qty.	Description
1	547027	1	Splined Shaft (2" dia.; 1-1/4" pilot)
2	*	1	Hair Pin
3	549635	1	Hydraulic Jack Assembly
4	542407	1	Pin
5	542405	2	Spacer Tube
6	*	2	Retaining Ring
7	542390	1	Lift Arm
8	542426	4	Caster (3-1/2")
9	540408	1	Left Leg
10	*	6	Jam Nut
11	*	6	Lock Washer (5/8")
12	542386	3	Pin
13	*	4	Hex Nut (M12 x 1.75)
14	*	4	Spring Washer (7/16")
15	*	1	Hex Hd. Cap Screw

Item No.	Part No.	Qty.	Description
16	548737	1	Lift Arm Tube
17	540407	1	Right Leg
18	540416	1	Load Block Weldment
19	547026	1	Leveling Arm
20	542383	6	Retaining Ring
21	542427	1	Head Support Pin
22	540417	1	Head Assembly
23	549260	1	Handle
24	542396	2	Load Block Leg
25	542393	2	Extension Spring
26	542395	1	Pin
27	542420	4	Spacer
28	*	1	Grease Zerk
<b>Parts Included but not Shown</b>			
	218297	2	Warning Decal
	548877	1	Logo Decal

### No. 540417 Head Assembly

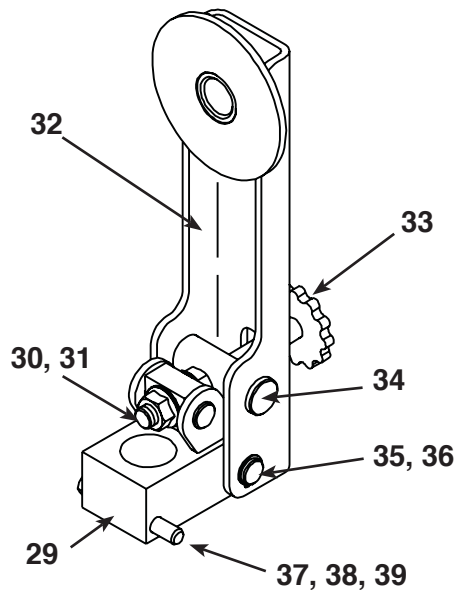

Item No.	Part No.	Qty.	Description
29	540405	1	Swivel Block
30	542431	1	Spacer
31	*	2	Hex Nut (1/2-13)
32	540409	1	Clutch Shaft Arm
33	546995	1	Knob
34	542425	1	Threaded Trunnion
35	542418	1	Pin
36	*	2	Retaining Ring
37	546994	1	Lock Pin
38	*	1	Hex Locknut
39	*	1	Compression Spring

Items marked with an asterisk (\*) are included in Hardware Kit No. 549763.

Refer to any operating instructions included with the product for detailed information about operation, testing, disassembly, reassembly, and preventive maintenance.  
 Items found in this parts list have been carefully tested and selected by OTC. **Therefore: Use only OTC replacement parts!**  
 Additional questions can be directed to the OTC Technical Services Department.

## Assembly Instructions

(Item numbers refer to the parts list illustration.)

1. Remove the retaining ring, pin, and spacers (Items 4, 5, & 6) from the lift arm.
2. Loosen the bolt (15) and remove the tag from the load block (18).
3. Install the hydraulic unit (3) into the load block until the piston bottoms, with the recessed area in the piston pointing up toward the bolt. See Figures 1 and 2.

**IMPORTANT: To prevent damage to equipment and to make the clutch handler function correctly, the bolt must rest in the recessed area of the piston.**

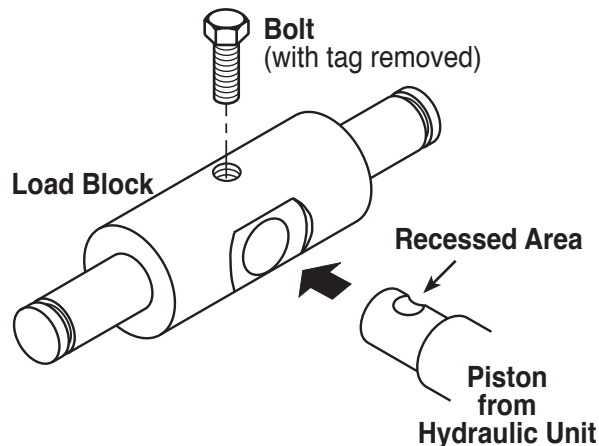

Figure 1

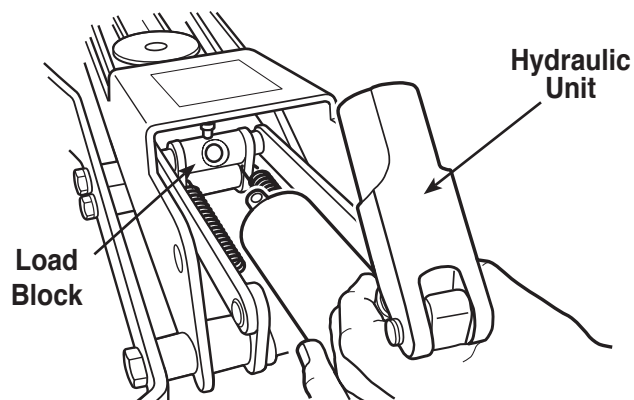

Figure 2

4. Use a 7/16" wrench to snug the bolt against the piston. See Figure 3.
5. Align the mounting holes in the hydraulic unit with the holes in the clutch handler frame. **NOTE: Use the hydraulic control valve to move the piston in/out for easier alignment.**
6. Insert the pin (4) through the frame, assemble one spacer (5), continue pushing the pin through the hydraulic unit, assemble the other spacer, and push the pin out through the frame. Attach a retaining ring (6) to each end of the pin. See Figure 4.
7. Install casters (8) to the frame with lockwashers and nuts (13 & 14) assembled on top of the frame. Use an 3/4" wrench to tighten the nuts.
8. Thread the handle into the head of the hydraulic unit.
9. Close the control valve, and pump the handle to raise the head assembly and lift arm.
10. Install the splined shaft (1) using the hair pin (2) provided.

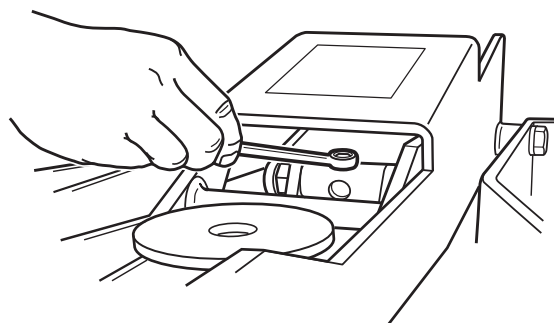

Figure 3

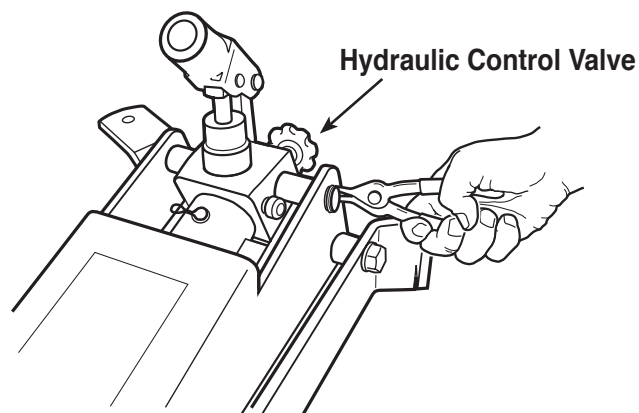
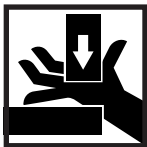

Figure 4



## Safety Precautions



**CAUTION:** To prevent personal injury and/or damage to equipment,

- If the operator cannot read English, operating instructions and safety precautions must be read and discussed in the operator's native language.
- Wear eye protection that meets ANSI Z87.1 and OSHA standards.
- Never exceed the rated lifting capacity of the clutch handler.
- Never move the clutch handler with the load any higher off the ground than necessary.
- Move the clutch handler cautiously around corners because it could tip.
- **SLOWLY** turn the hydraulic control valve counterclockwise to release hydraulic pressure. Lowering the lift arm too quickly could cause equipment damage, loss of load, and / or personal injury.
- Use only those adapters and replacement parts provided by the manufacturer.
- Never modify the unit or adapters.
- Stay clear of the clutch handler's pinch points as you raise and lower the lift arm.

## Operating Instructions

### Clutch Removal

1. Sparingly apply lubricant to the area of the splined shaft shown in Figure 5.
2. If there isn't enough clearance to roll the clutch handler under the vehicle, raise the vehicle's front end. Position the clutch handler under the vehicle.
3. Cycle the pump until the head assembly is tilted forward. If necessary, push the lock pin to rotate the head assembly at 90° intervals. Continue cycling the pump to raise the lift arm. **Note:** The lock pin is also used to install or remove the head assembly.
4. Use the adjusting knob to change the angle of the splined shaft so it matches the angle of the vehicle clutch assembly. **IMPORTANT: To prevent equipment damage, do not use an impact wrench on the adjusting knob.**
5. Insert the splined shaft into the clutch assembly. Use the adjusting knob to further improve the alignment of the splined shaft. The splines must completely engage the clutch discs before you remove the clutch assembly.
6. Remove the mounting bolts on the pressure plate.
7. Pull the clutch handler and clutch assembly away from the flywheel.
8. Use the lock pin to turn the head assembly until the splined shaft is facing forward. ("Forward" means the splined shaft is pointing AWAY from the pump handle and IN-LINE with the jack frame.) **IMPORTANT: The splined shaft must be facing forward to keep the clutch assembly on the clutch handler as it folds down.**
9. Slowly release pressure to lower the clutch assembly, keeping clear of the clutch handler's pinch points as it folds down. See Figure 6.

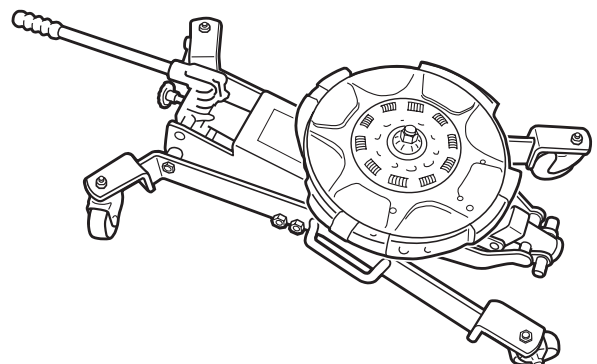
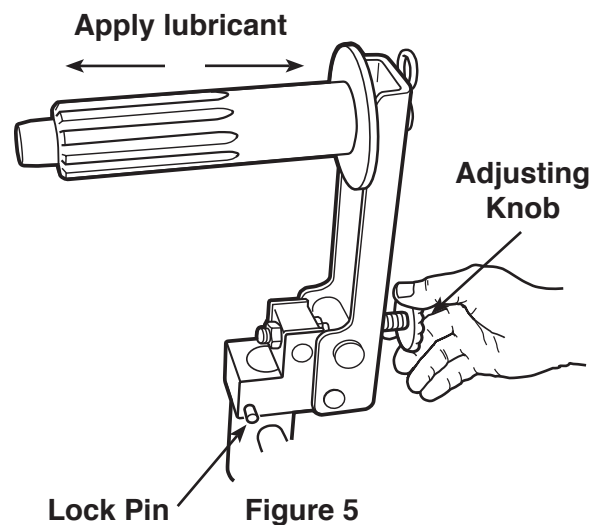

### 15-1/2" Clutch Installation

1. Sparingly apply lubricant to the area of the splined shaft shown in Figure 5.
2. **NOTE:** The clutch handler should be completely collapsed at this point. Position the pressure plate, clutch, discs, and spacer onto the clutch handler's splined shaft. **IMPORTANT:** The splined shaft must pass completely through all components of the clutch assembly.
3. If there isn't enough clearance to roll the clutch handler under the vehicle, raise the vehicle's front end. Position the clutch handler under the vehicle.
4. Cycle the pump until the head assembly is tilted forward. If necessary, push the lock pin to rotate the head assembly (360° with 90° stops). Continue cycling the pump to raise the lift arm.
5. Use the adjusting knob to change the angle of the clutch assembly to match the flywheel. Roll the clutch handler forward to insert the splined shaft pilot into the flywheel pilot bearing.
6. Bolt the clutch to the flywheel.
7. Slightly release lift arm pressure. **NOTE:** If it is difficult to remove the clutch handler from the clutch assembly, adjust the alignment of the splined shaft by using the adjusting knob.
8. Back the handler away. Use the lock pin to rotate the head assembly to face forward. Slowly release pressure to lower the lift arm to floor level, keeping your hands clear of pinch points as the clutch handler folds down.

### 14" Clutch Installation

1. Sparingly apply lubricant to the area of the splined shaft shown in Figure 5.
2. Place the new front clutch disc and intermediate plate into the pot type flywheel. See Figure 7. Load the pressure plate and new rear disc on the clutch handler splined shaft. **NOTE:** The clutch handler should be completely collapsed at this point.
4. If there isn't enough clearance to roll the clutch handler under the vehicle, raise the vehicle's front end. Position the clutch handler under the vehicle.
5. Cycle the pump until the head assembly is tilted forward. If necessary, push the lock pin to rotate the head assembly (360° with 90° stops). Continue cycling the pump to raise the lift arm to the correct height to engage the front disc spline.
6. Use the adjusting knob to change the angle of the clutch assembly to match the flywheel. Roll the clutch handler forward to insert the splined shaft. Rotate the splined shaft for correct engagement of the clutch disc. **NOTE:** The front clutch disc in the flywheel is slightly lower than the center line of the pilot bearing. It may be necessary to raise the lift arm to correctly align the splined shaft with the pilot bearing. See Figure 8.
7. Bolt the clutch to the flywheel.
8. Slightly release lift arm pressure. **Note:** If it is difficult to remove the clutch handler from the clutch assembly, adjust the alignment of the splined shaft by using the adjusting knob.
9. Back the handler away, use the lock pin to rotate the head assembly to face forward, and slowly release pressure to lower the lift arm to floor level, keeping your hands clear of pinch points as the clutch handler folds down.

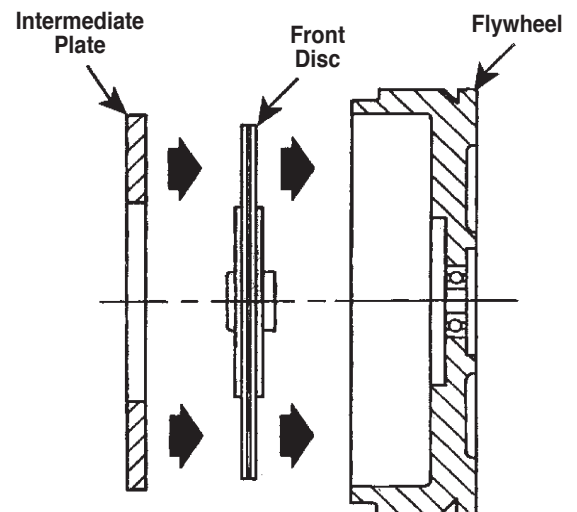

Figure 7

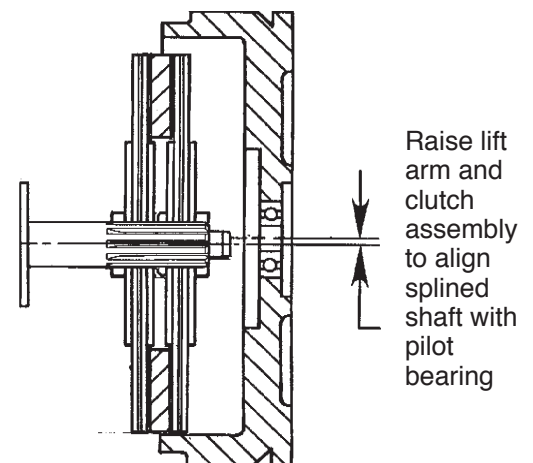

Figure 8