



655 Eisenhower Drive
 Owatonna, MN 55060 USA
 Phone: (507) 455-7000
 Tech. Serv.: (800) 533-6127
 Fax: (800) 955-8329
 Order Entry: (800) 533-6127
 Fax: (800) 283-8665
 International Sales: (507) 455-7223
 Fax: (507) 455-7063

Form No. 551692

Parts List and
 Operating Instructions for:

206391

Ford 6.0L and 6.4L Engine Adapter

(use with OTC 1735, 1735A, and 1735B engine stands)

Maximum Capacity: 2,000 lbs. (907 kg)

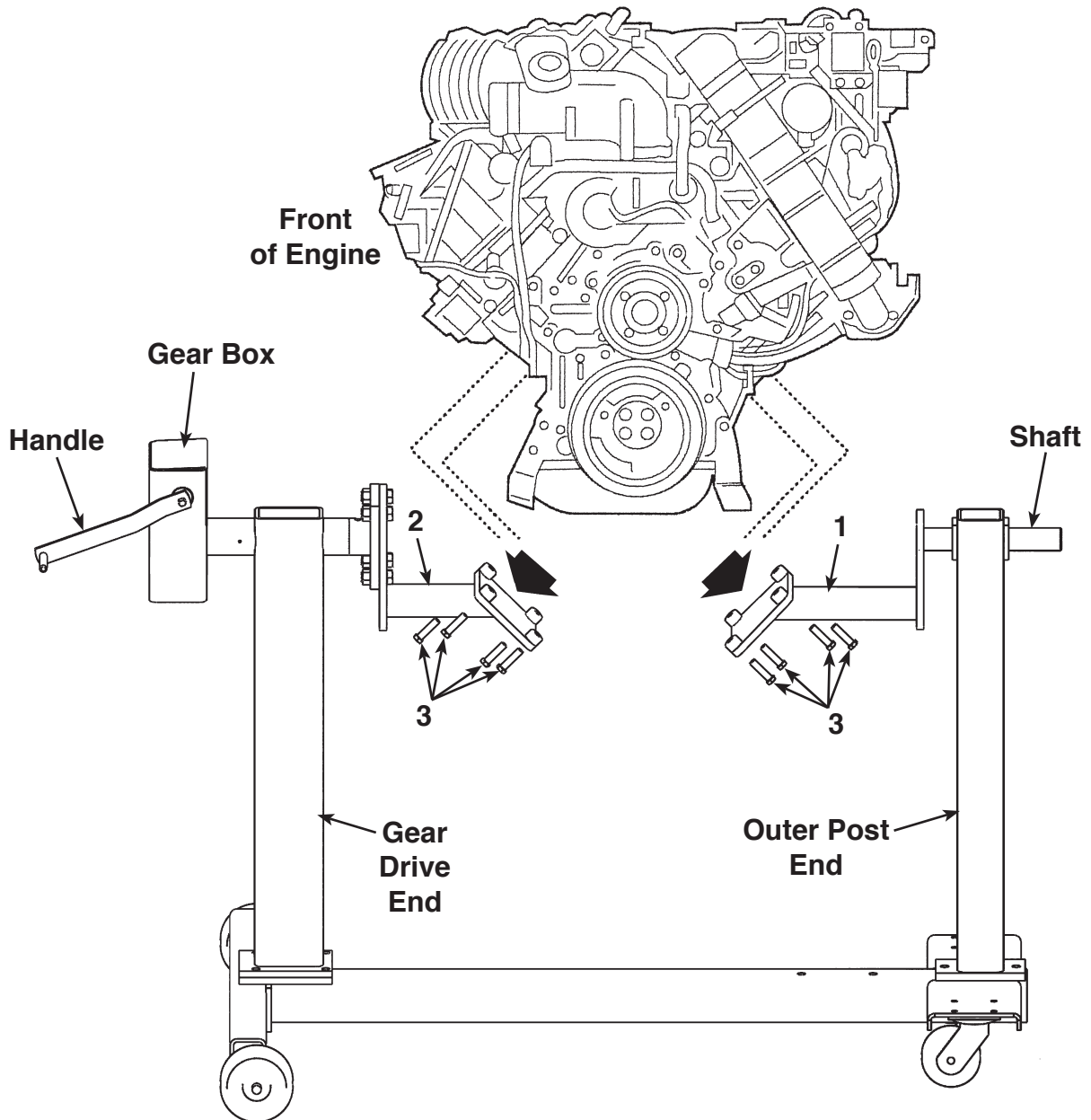

Item No.	Part No.	Qty.	Description
1	551393	1	Engine Adapter (driver's side)
2	551392	1	Engine Adapter (passenger's side)
3	568392	1	Hex Hd. Bolt Kit (10 mm; 8 bolts)

Sheet No. 1 of 3

Issue Date: Rev. C, March 1, 2013

Safety Precautions



WARNING: To prevent personal injury and/or equipment damage,



- Read, understand, and follow all instructions and safety precautions. If the operator cannot read these instructions, operating instructions and safety precautions must be read and discussed in the operator's native language.



- Wear eye protection that meets ANSI Z87.1 and OSHA standards.
- Do not exceed the rated capacity.
- No alterations shall be made to this product.
- Use these adapters on the OTC 1735, 1735A, and 1735B engine stands only.
- Use these adapters on Ford 6.0L and 6.4L engines only.
- Use only OTC approved bolts (provided) to attach the adapters to the engine stand and the engine to the adapters.

Setup

1. Remove the adapters from the gear drive end and outer post end shafts of the OTC 1735, 1735A, or 1735B engine stand. Retain the bolts and lockwashers to use with the Ford engine adapters.
2. Adjust the outer post end of the engine stand to its maximum length and secure with mounting bolts.
3. Install the driver's side engine adapter (No. 551393) to the outer post end shaft of the engine stand.
4. Install the passenger's side engine adapter (No. 551392) to the gear box end shaft of the engine stand. Secure to the shaft with bolts, nuts, and lockwashers.

Operating Instructions

1. Read, understand, and follow the operating instructions for the engine stand you are using (Form No. 102505 for 1735; Form No. 538577 for 1735A; Form No. 565726 for 1735B).
2. Read, understand, and follow the vehicle manufacturer's specifications for the correct removal and installation of Ford 6.0L and 6.4L diesel engines.
3. Begin by planning your actions based on adapting the engine stand (with OTC No. 206391 adapters) to the engine – not adapting the engine to the engine stand.

Using a shop crane, remove the engine from the vehicle. Support the engine from the shop crane at a height just high enough so the engine stand with adapters will not have to be raised more than six inches to reach the adapters.

4. Align the holes of the gear box side adapter first with the corresponding engine mounting bosses. Install four of the metric bolts (provided) and tighten finger tight. Slide the outer post end adapter to the engine. Align the holes of the adapter to the engine mounting bosses and install four metric bolts finger tight. Wrench tighten all bolts.

CAUTION: To prevent thread damage, avoid cross-threading bolts by *carefully* aligning holes, starting threads, and tightening.

5. Using the shop crane, slowly lower the engine and engine stand to the floor.



WARNING: To prevent personal injury and/or equipment damage,

- The engine stand must be lowered onto a hard, level surface only.
- To prevent a shock load to the engine stand, rotate the engine stand gear box handle *slowly* when rotating a fully dressed engine.