



655 EISENHOWER DRIVE
OWATONNA, MN 55060 USA
PHONE: (507) 455-7000
TECH. SERV.: (800) 533-6127
FAX: (800) 955-8329
ORDER ENTRY: (800) 533-6127
FAX: (800) 283-8665
INTERNATIONAL SALES: (507) 455-7223
FAX: (507) 455-7063

Form No. 563375

Parts List &
Operating Instructions
for:

6703

Line Fluid Stopper Kit

Application: Quickly stops fluid from separated fuel hoses.
Available for injection hose or fuel supply hose adapters.



Explanation of Safety Signal Words

The safety signal word designates the degree or level of hazard seriousness.

! **DANGER:** Indicates an imminently hazardous situation which, if not avoided, will result in death or serious injury.

! **WARNING:** Indicates a potentially hazardous situation which, if not avoided, could result in death or serious injury.

! **CAUTION:** Indicates a potentially hazardous situation which, if not avoided, may result in minor or moderate injury.

CAUTION: Used without the safety alert symbol indicates a potentially hazardous situation which, if not avoided, may result in property damage.

Sheet No. 1 of 2

Issue Date: Rev C March 10, 2014

Safety Precautions



CAUTION: To prevent personal injury and/ or property damage,



- Study, understand, and follow all safety precautions and operating instructions before using the Line Fluid Stopper Kit. If the operator cannot read instructions, operating instructions and safety precautions must be read and discussed in the operator’s native language.



- Wear ear and eye protection that meet ANSI and OSHA standards.



- Fuel leakage could cause a fire.
- Release fuel system pressure before servicing fuel system components.
- To avoid spilling fuel on the engine, wrap a shop towel around pressure tap fittings when connecting or disconnecting adapters. Pressurized fuel can create a fire hazard. Dispose of the shop towel correctly.
- Protect painted surfaces from fuel or cleaner fluid spills.
- Observe normal precautions for working with flammable liquids: no smoking, open flames, electrical sparks, etc. Have a Class B fire extinguisher available while working on fuel systems.
- Do not modify any components of the Line Fluid Stopper Kit. Do not replace any components of the kit except as specified by the manufacturer.

Parts List

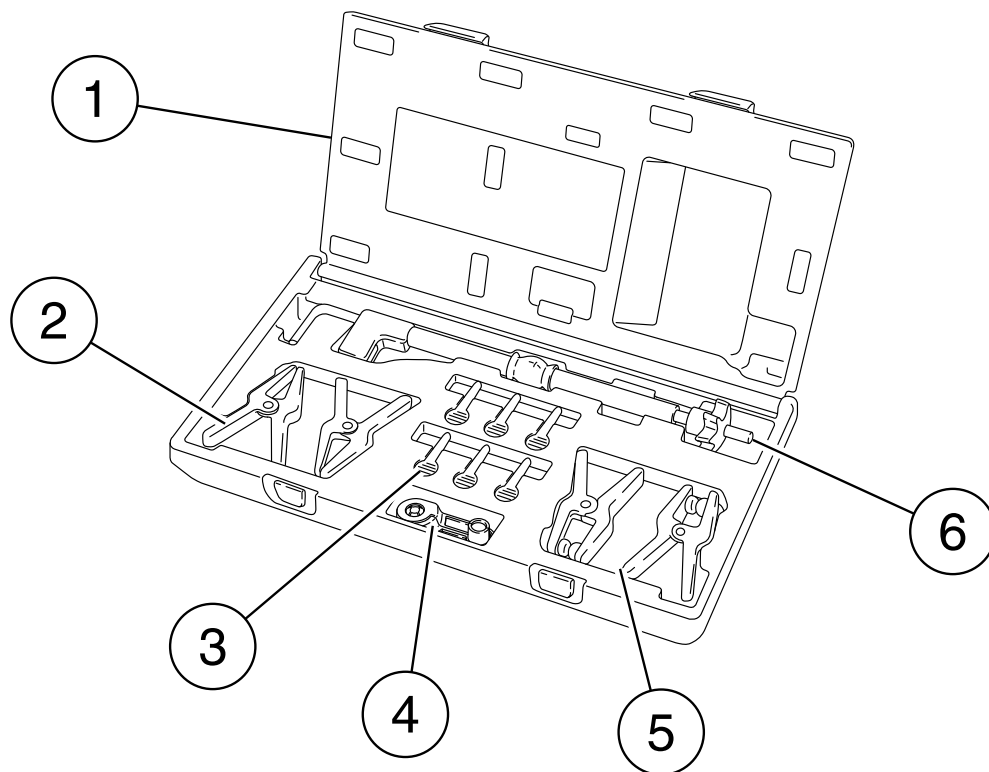

Item No.	Part No.	Qty.	Description
----------	----------	------	-------------

1		1	Black molded case
2	6703-2	2	Steel line fluid stopper
3	6703-3	6	Line plug fluid stopper

Item No.	Part No.	Qty.	Description
----------	----------	------	-------------

4		1	Fuel line separator
5	6703-1	2	Banjo line fluid stopper
6		1	Long-reach pinch-off tool

Operation Instructions

Item numbers (x) refer to the parts list.

Steel Line Fluid Stopper

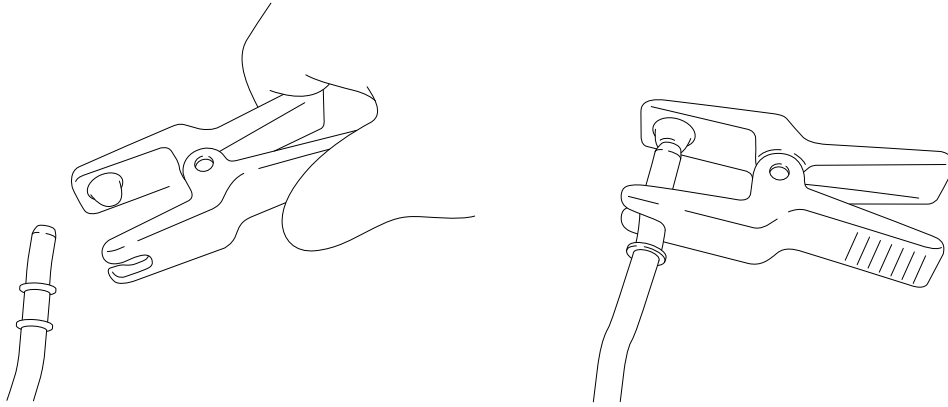

1. Pinch handles of line stopper (2) together to open.
2. Install line stopper on steel line.

Banjo Line Fluid Stopper

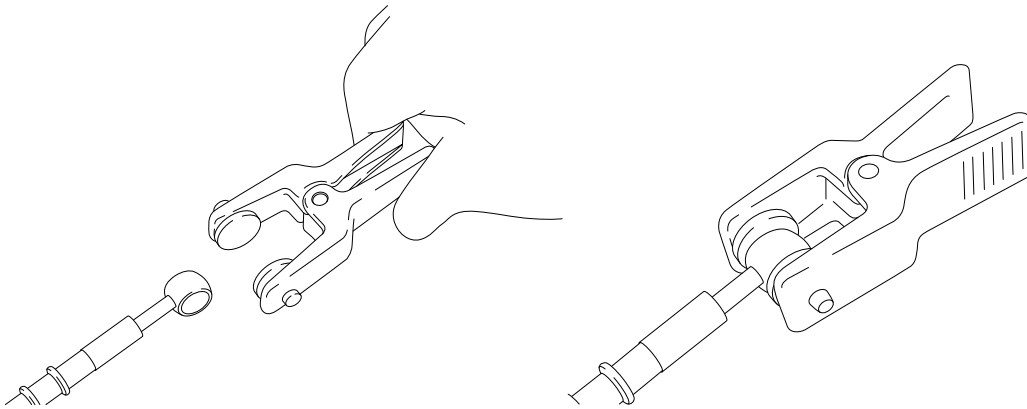

1. Pinch handles of line stopper (5) together to open.
2. Install line stopper on each side of banjo fitting.

Long-Reach Pinch-off Tool

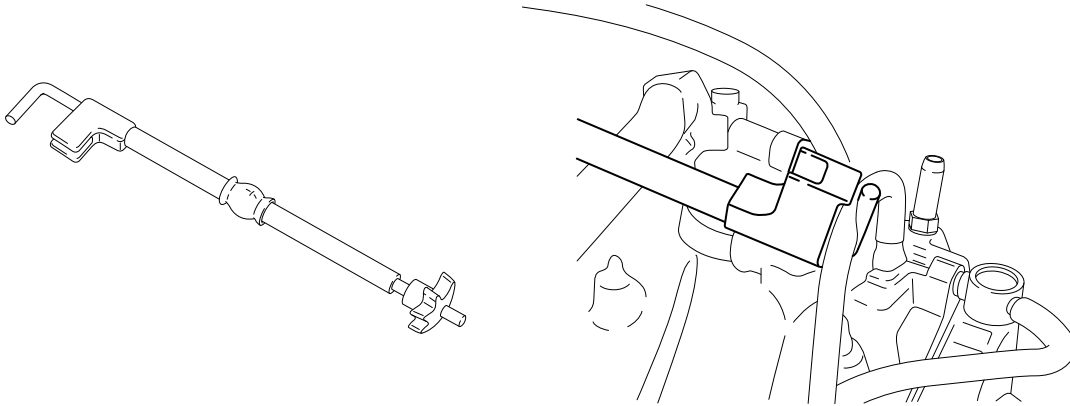

1. Open pinch-off tool (6).
2. Position tool on hose.
3. Tighten tool sufficiently to prevent flow.

Line Plug Fluid Stopper

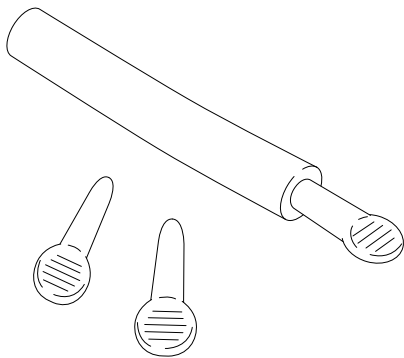

1. Tightly insert the appropriate size line plug (3) into the hose end.

Fuel Line Separator

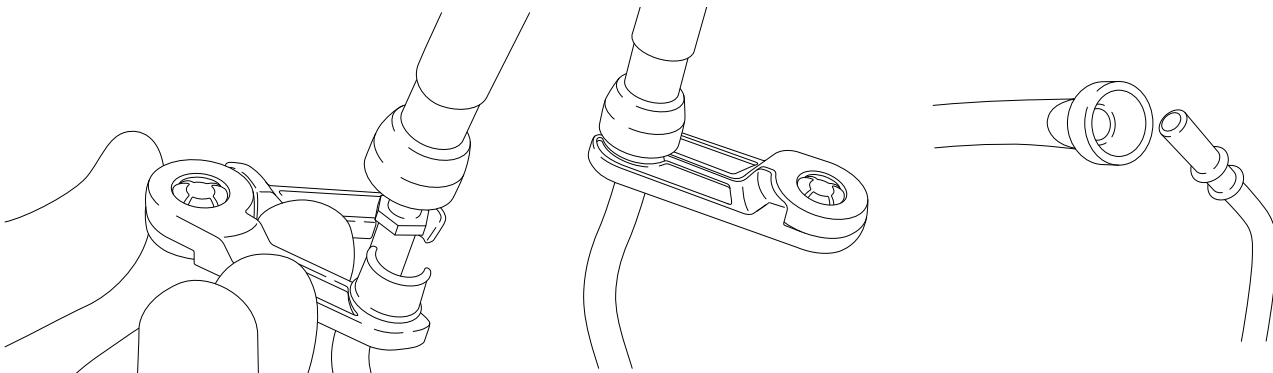

1. Open the fuel line separator (4), place it around the pipe, and close.
2. Push the fuel line separator against the hose end to separate.