



655 Eisenhower Drive
Owatonna, MN 55060-0995 USA
Phone: (507) 455-7000
Tech. Serv.: (800) 533-6127
Fax: (800) 955-8329
Order Entry: (800) 533-6127
Fax: (800) 283-8665
International Sales: (507) 455-7223
Fax: (507) 455-7063

Form No. 565353

Assembly &
Operating Instructions for: 6591-1

StrutTamer Adapters

Application: 1996–2008 Ford Taurus and Mercury Sable



Use these adapters with OTC Part No. 6591 StrutTamer Extreme.

Explanation of Safety Signal Words

The safety signal word designates the degree or level of hazard seriousness.



DANGER: Indicates an imminently hazardous situation which, if not avoided, will result in death or serious injury.



WARNING: Indicates a potentially hazardous situation which, if not avoided, could result in death or serious injury.



CAUTION: Indicates a potentially hazardous situation which, if not avoided, may result in minor or moderate injury.

CAUTION: Used without the safety alert symbol indicates a potentially hazardous situation which, if not avoided, may result in property damage.

Sheet No. 1 of 2

Issue Date: Rev A, June 18, 2012



Safety Precautions

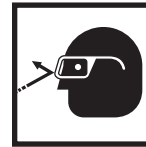

WARNING: Spring compression creates a potentially dangerous situation because of the energy stored between the spring mounts. Failure to correctly position the strut assembly in the tool could result in serious injury from a sudden release of strut assembly parts. To prevent personal injury,

- Study, understand, and follow the safety precautions and operating instructions included with the strut spring compressor. If the operator cannot read these instructions, operating instructions and safety precautions must be read and discussed in the operator's native language.
- Wear eye protection that meets ANSI Z87.1 and OSHA standards.
- Use this equipment for automotive strut springs only.
- Check the condition of the strut spring compressor before each use; do not use the equipment if it is damaged, worn, or modified.
- Align the strut assembly before compressing. The spring should be parallel to the forcing screw and on the centerline of the foot support.
- Release and reposition the strut assembly if it is difficult to compress the spring, or if the spring bows.
- Compress the spring only until it is loose in its spring mounts. Stop compressing if the spring or the arms bottom out.
- Do not remove the piston rod nut until the spring is compressed enough to be loose in the mount.

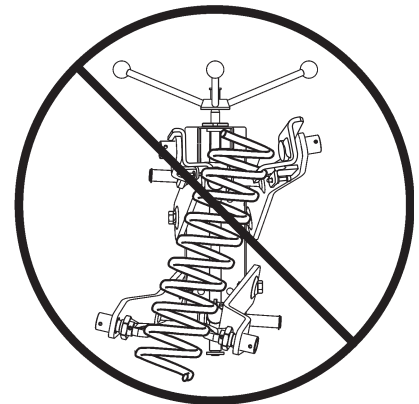

Setup

1. Remove the upper right and left jaws from the strut spring compressor by tapping out the roll pins. See Figure 1. Discard roll pins.
2. With the adapters positioned as shown in Figure 2, insert the adapter brackets into the upper arms and secure in place by inserting the pins (provided) into the front side of the pin holes.

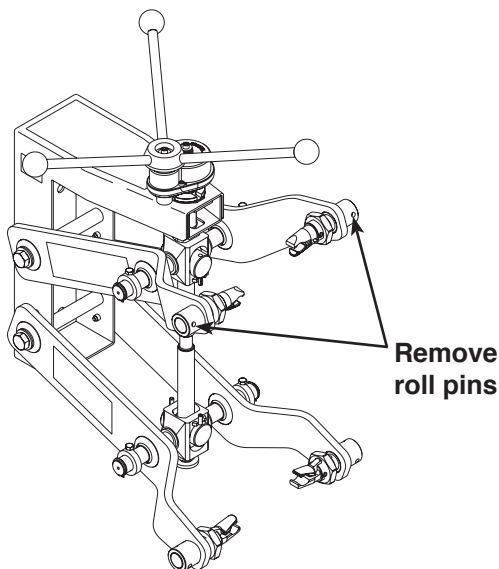

Figure 1

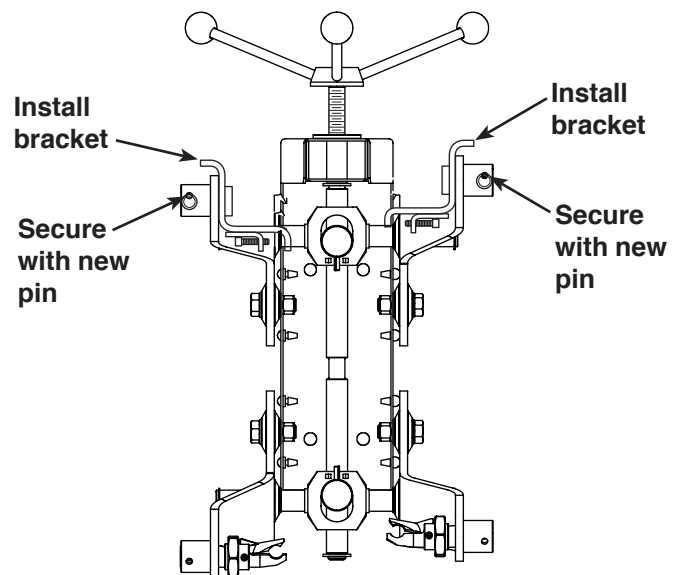
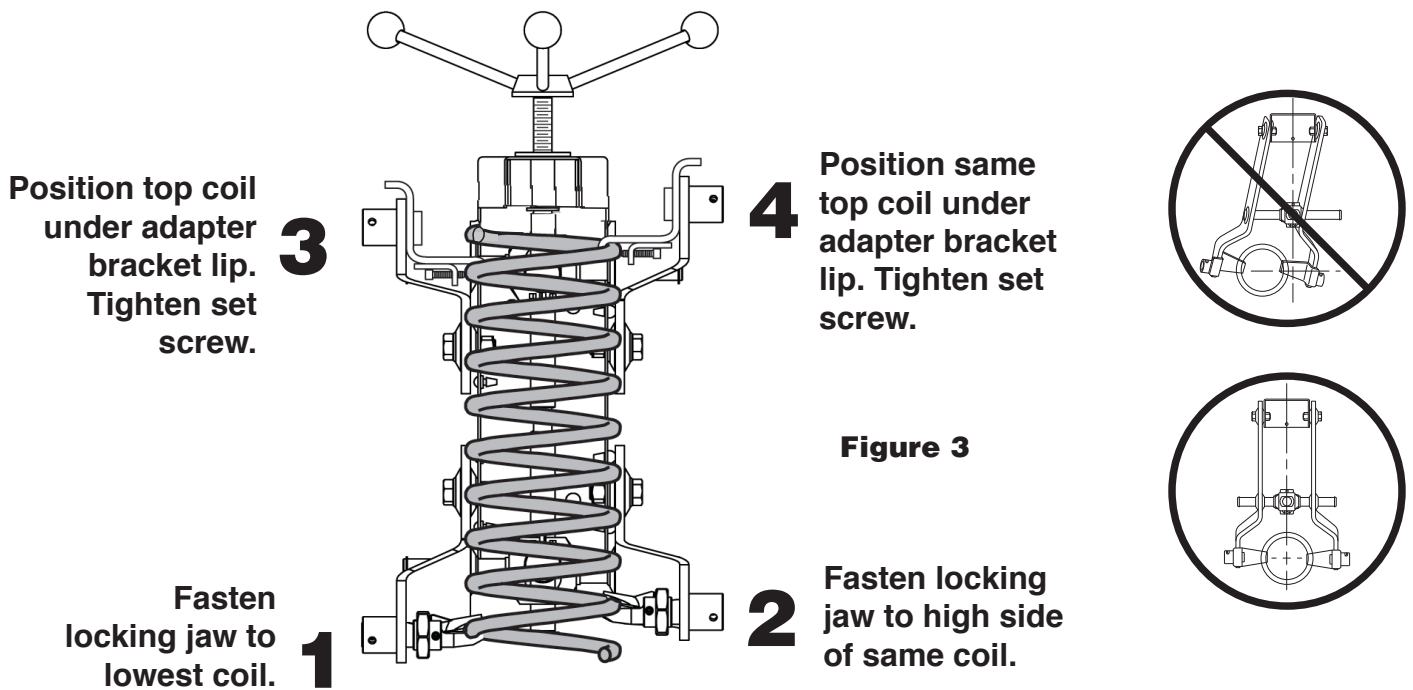

Figure 2

Operating Instructions

Removal

1. Refer to the vehicle service manual, and follow the manufacturer's recommended procedure to remove the strut assembly from the vehicle.
2. Mark the position of the spring in relation to the lower platform and top mount to note the correct position for installation.
3. Choose the lowest possible spring coil to insert into the lower left jaw. Hand tighten the locknut. See Figure 3.
4. Load the opposite side of the same coil in the lower right jaw and hand tighten the locknut. *Note: It may be necessary to move the compressor arms to access the coil.*
5. Choose the highest possible spring coil to position under the lip of the upper left adapter bracket. Hand tighten the adapter bracket set screw to contact the coil.
6. Load the opposite side of the same coil by positioning it under the lip of the upper right adapter bracket. Hand tighten the adapter bracket set screw to contact the coil.
7. Before servicing the strut assembly, **align the strut spring with the forcing screw** on the strut spring compressor as shown in Figure 3.



8. Equally space the top arms on the top trunnion as shown in Figure 4. The forcing screw must be centered between the two top arms.
9. Operate the actuating screw to compress the spring only until the strut cartridge is loose in the spring mounts. **IMPORTANT: The spring should be compressed only until the strut tube is loose in the spring.**
10. Remove the piston rod nut, and service the strut as required.

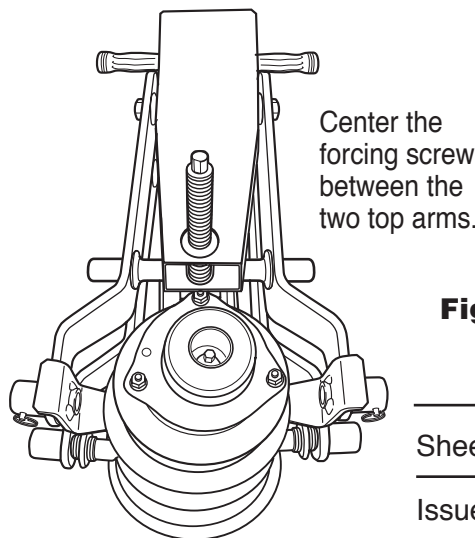

Installation of a New Spring

1. Remove the old spring from the strut tool. Install the new spring into the StrutTamer tool (OTC Part No. 6591), using the lower locking jaws and upper adapter brackets as shown in Figure 3. Compress the spring.
2. Align the lower spring tip in its receptacle in the lower platform. Replace the top mount. Attach the piston rod nut, and torque it to the specifications listed in the vehicle service manual.
3. Check the alignment of both spring coil tips to the mounting platforms. Decompress the spring.
4. Follow the manufacturer's procedure to reinstall the strut assembly.

Tech Tip

The top trunnion has been designed as an indicator of spring compression. When the top trunnion is centered as shown in Figure 5, the tool is not applying any force to the strut assembly.

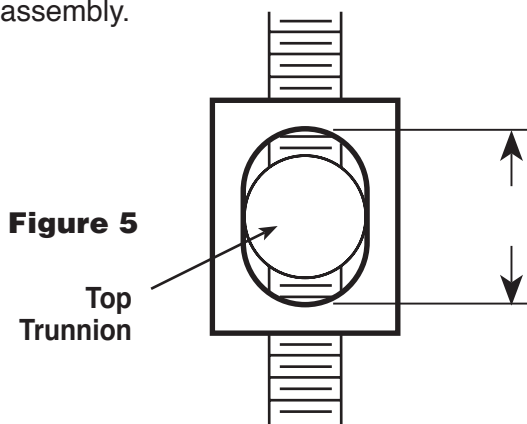

Figure 5
Top Trunnion

Maintenance

1. Use vehicle chassis grease to keep the forcing screw lubricated.

Reassembly Procedure

Follow this procedure if it's necessary to remove the forcing screw, top trunnion, or bottom trunnion for repair or replacement (refer to OTC parts list No. 555231).

1. Ensure both trunnions are driven in approximately one inch from the edge of the forcing screw's bottom threads and one inch from the edge of the top threads, respectively, before remounting the arms onto the trunnions. See Figure 6.

Reassembly of Jaws for Different Applications

To reinstall the upper jaws to the StrutTamer tool:

1. Pull the pins holding the adapters, and remove the adapters.
2. Install the jaws into the arms and secure with the new pins.
NOTE: Install the pins from the back side of each arm into the mounting slot. See Figure 7.

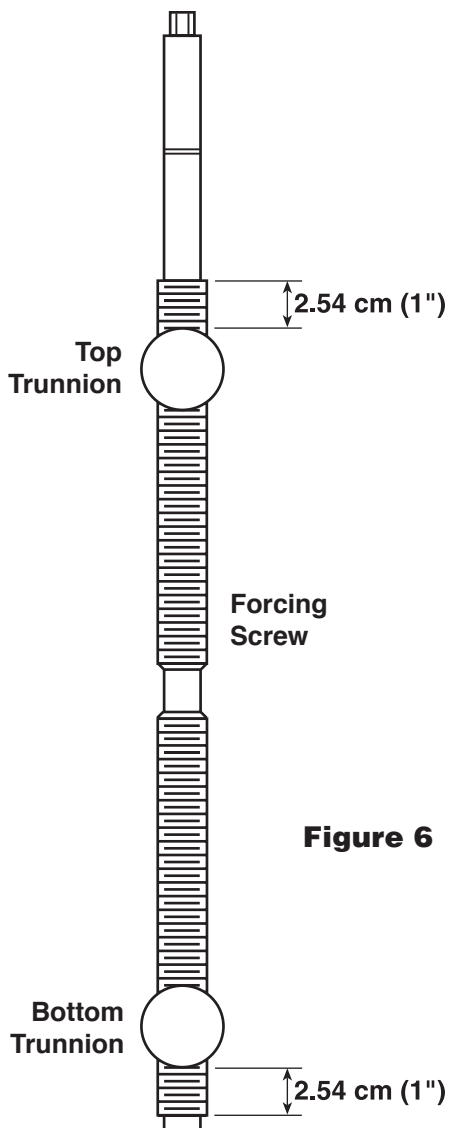

Figure 6

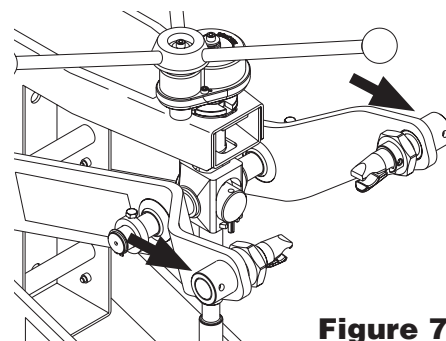

Figure 7