

Parts List & Operating Instructions for No. 6683 Ford 1.6L Engine Cam Tool Kit

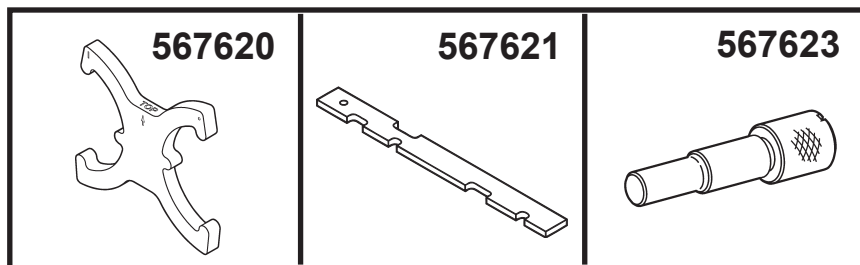

Ford Tool Application Chart						
Year	Model	Engine	Tool Description	Part No.	Ford American Part No.	Ford Global Part No.
2013-2014	Escape	1.6L	VCT Alignment Tool	567620		303-1097
			Camshaft Holding Timing Tool	567621		303-376B
			Crankshaft TDC Timing Pin	567623		303-748
2011-2014	Fiesta	1.6L	VCT Alignment Tool	567620		303-1097
			Camshaft Holding Timing Tool	567621		303-376B
			Crankshaft TDC Timing Pin	567623		303-748
2013-2014	Fusion	1.6L	VCT Alignment Tool	567620		303-1097
			Camshaft Holding Timing Tool	567621		303-376B
			Crankshaft TDC Timing Pin	567623		303-748
2013-2014	Transit	1.6L	VCT Alignment Tool	567620		303-1097
			Camshaft Holding Timing Tool	567621		303-376B
			Crankshaft TDC Timing Pin	567623		303-748

Get parts at OTCparts.com



Form No. 567787

Sheet No. 1 of 2

Issue Date: July 25, 2014 Rev. B

567620 Ford VCT Alignment Tool

Application: 2011 – 2014 1.6L Escape, Fusion, Transit
2013 – 2014 1.6L Fiesta

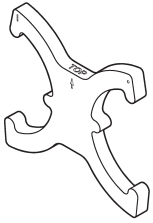

CAUTION: Do not loosen or remove the crankshaft pulley bolt without first installing the 567620. The crankshaft pulley and the crankshaft timing sprocket are not keyed to the crankshaft. Before any repair requiring loosening or removal of the crankshaft pulley bolt, the crankshaft, and camshafts must be locked in place by the 567620, otherwise engine damage may occur.

NOTE: If camshaft service is required, install the 567621 Ford Camshaft Holding Timing Tool into the end of camshaft first.

1. The timing marks on the camshaft phaser and sprocket must be at the 12 o'clock position.
2. Install the 567620 to maintain this position.
3. Perform camshaft service as required according to vehicle service manual.

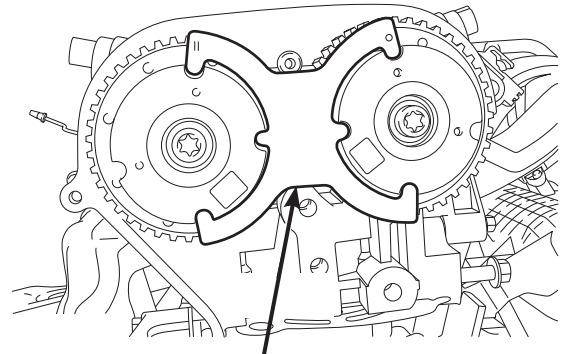

No. 567620

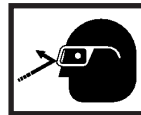

WARNING: Wear eye protection that meets ANSI Z87.1 and OSHA standards.

567621 Ford Camshaft Holding Timing Tool

Application: 2011 – 2014 1.6L Escape, Fusion, Transit
2013 – 2014 1.6L Fiesta

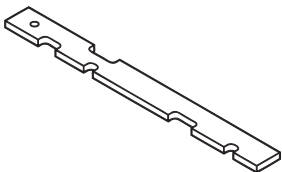

NOTE: Use an open-ended wrench to hold the camshafts by the hexagon to prevent the camshafts from turning.

1. Rotate each camshaft until the 567621 fits into the end of the camshafts.

NOTE: When 567621 is installed, the timing marks of the camshaft phaser and sprocket must be at the 12 o'clock position.

2. Perform camshaft service as required according to vehicle service manual.

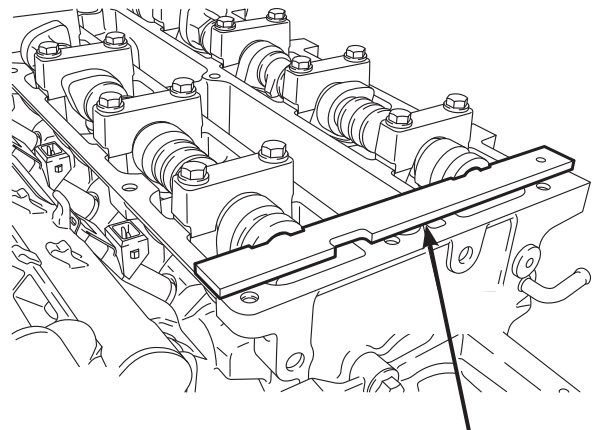

No. 567621

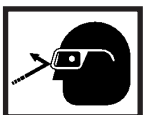

WARNING: Wear eye protection that meets ANSI Z87.1 and OSHA standards.

567623 Ford Crankshaft TDC Timing Pin

Application: 2011 – 2014 1.6L Escape, Fusion, Transit
2013 – 2014 1.6L Fiesta

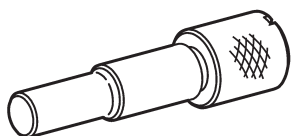

NOTE: The 567623 Crankshaft TDC Timing Pin will contact the crankshaft and prevent it from turning past TDC. However, the crankshaft can still be rotated in the counterclockwise direction. The crankshaft must remain at the TDC position during the crankshaft pulley removal and installation.

1. Remove the engine plug bolt.

NOTE: Rotate the crankshaft in the clockwise direction only.

2. Install the 567623 Crankshaft TDC Timing Pin in the hole.
3. Rotate the crankshaft until it contacts the 567623 Crankshaft TDC Timing Pin.
4. Perform crankshaft or timing service as required according to vehicle service manual.

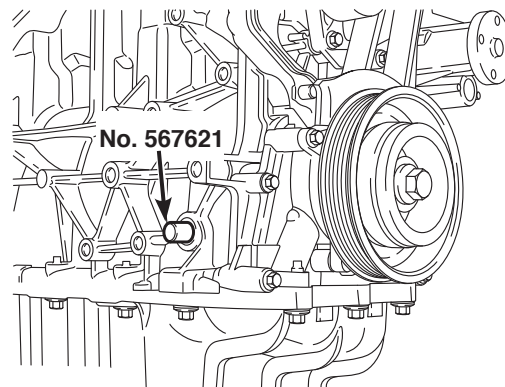

! WARNING: Wear eye protection that meets ANSI Z87.1 and OSHA standards.

Form No. 567787

Sheet No. 2 of 2

Issue Date: July 25, 2014 Rev. B