



655 Eisenhower Drive
Owatonna, MN 55060 USA
Phone: (507) 455-7000
Tech. Serv.: (800) 533-6127
Fax: (800) 955-8329
Order Entry: (800) 533-6127
Fax: (800) 283-8665
International Sales: (507) 455-7290
Fax: (507) 455-7063

Form No. 572044

Parts List &
Operating Instructions for: 1591B

Portable Air Lift Jack/Support Stand

Max. Capacity: 10 Tons at 200 PSI

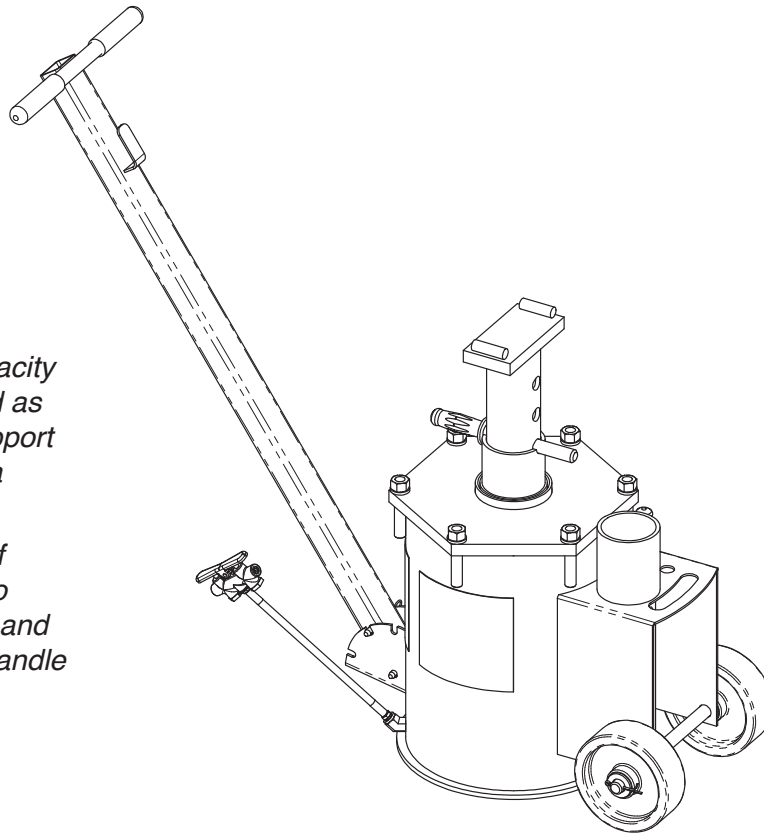

Description:

The 1591B 10-ton capacity air lift jack can be used as a lifting device and support stand when servicing a vehicle.

It has a height range of 18-3/4 in. (47.63 cm) to 50-1/2 in. (128.27 cm) and features a 3-position handle and 8 ft. air hose.

Explanation of Safety Signal Words

The safety signal word designates the degree or level of hazard seriousness.



DANGER: Indicates an imminently hazardous situation which, if not avoided, will result in death or serious injury.



WARNING: Indicates a potentially hazardous situation which, if not avoided, could result in death or serious injury.



CAUTION: Indicates a potentially hazardous situation which, if not avoided, may result in minor or moderate injury.

CAUTION: Used without the safety alert symbol indicates a potentially hazardous situation which, if not avoided, may result in property damage.

Sheet No. 1 of 2

Issue Date: Rev. C, January 20, 2015

Safety Precautions



WARNING: To prevent personal injury and / or property damage:



- Read and understand the safety precautions and operating instructions before using the air lift jack. If the operator cannot read English, operating instructions and safety precautions must be read and discussed in the operator's native language.



- Wear eye protection that meets ANSI Z87.1 and OSHA standards.
- Do not modify the air lift jack or use attachments unless approved or supplied by OTC.



- A load must never exceed the maximum capacity of the jack.
- Before lifting a vehicle, release the parking brake, place the gear selector in neutral, and chock the wheels at the opposite end.
- Use the jack on a hard, level surface.
- Stay clear of a raised load.
- Release pressure SLOWLY.

Operating Instructions

1. Before lifting a vehicle, release the parking brake, place the gear selector in neutral, and chock the wheels at the opposite end.
2. Pin the lift handle into a preferred position for moving the air lift. Move the air lift jack into position under the vehicle frame.
3. Raise the lifting saddle and insert the pin into the hole that retains the saddle closest to the lifting point.
4. Set shop air pressure at 200 psi or less. Connect a shop air hose to the fitting on the jack's control valve.
5. Using the control valve lever, apply shop air until the jack saddle meets the load to be raised. Lifting saddle must cradle the lifting point by nesting around the frame, bumper, or bed. See Figure 1.
6. Continue applying shop air to raise the load to desired height. Then insert the second pin into the hole on the piston tube and SLOWLY release pressure until the load comes to rest on the pin.
7. To lower the load, raise the load until the pin in the piston tube can be removed. Then SLOWLY lower the load until the lifting saddle is clear of the load, and remove the pin in the lifting saddle.

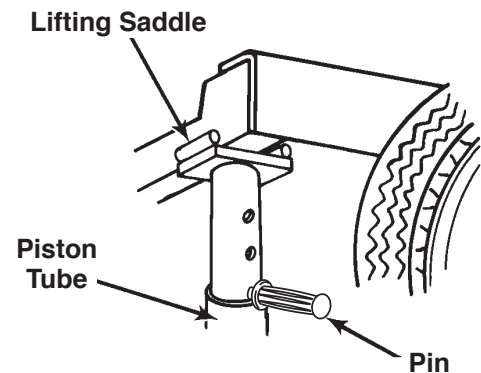

Figure 1

Maintenance

CAUTION: Water entering the jack from the air supply or through the top cover plate can collect in the bottom of the cylinder, and result in rust buildup on the cylinder wall. Drain water out of the jack on a regular basis by removing the 45° elbow fitting at the base of the cylinder, and tilting the jack until all the water is removed.

1. Lubricate the wheel shafts and center tube as needed with a high quality grease.
2. Inspect the air lift jack before each use. Keep the control valve and fittings clean. Keep the surface of the lifting saddle clean to ensure sufficient grip during a lift.
3. Periodically check the inlet air filter for debris. Clean or replace the filter when necessary.

Parts List

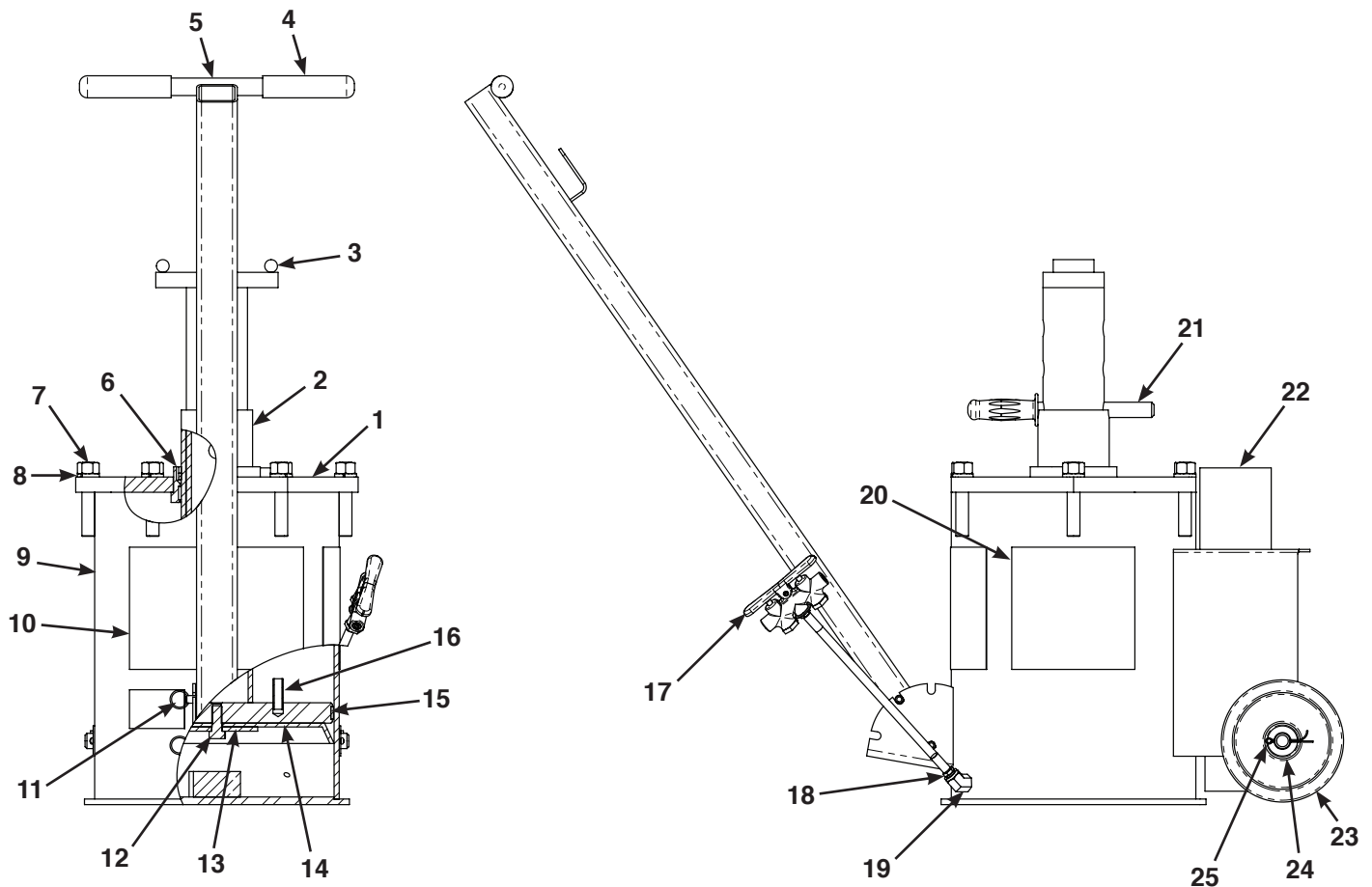

Item No.	Part No.	No. Req'd	Description
1	54425	1	Cover Plate
2	440223	1	Piston Assembly
3	48349	1	Saddle Tube
5	572977	1	Assembly Handle
6	217336	2	Wear Ring Kit
9	571653	1	Body Weldment
14	217164	1	U-cup Seal
15	217175	1	Bearing Strip
18	216296	1	Filter Disc
21	313881	2	Pin
22	48354	1	Extension Tube

Hardware Kit No. 572047

Item No.	No. Req'd.	Description
4	2	Handle Grip
7	6	Hex Nut (5/8-11; torque to 80-110 ft. lbs.)
8	6	Lock Washer (for 5/8 in. bolt)
10	1	Warning Decal
11	2	Cotterless Hitch Pin
12	1	Hex Hd. Cap Screw (1/2-13 x 1-1/4 in. lg.)
13	1	Washer
16	4	Pin
19	1	45° Fitting
20	1	Part Number Decal
24	4	Washer (for 3/4 in. bolt)

Valve and Hose Kit No. 564177

Item No.	No. Req'd.	Description
17	1	Air Valve / Hose Assembly

Wheel Kit No. 564178

Item No.	No. Req'd.	Description
23	2	Wheel (6 in. dia.)
25	2	Cotter Pin

Refer to any operating instructions included with the product for detailed information about operation, testing, disassembly, reassembly, and preventive maintenance.

Items found in this parts list have been carefully tested and selected by OTC. **Therefore: Use only genuine OTC replacement parts.**

Additional questions can be directed to our Technical Service Dept.

Get parts at OTCparts.com



Get parts at OTCparts.com